



X1-MINI G4

0.6 kW / 0.7 kW / 0.8 kW / 1.1 kW / 1.5 kW / 2.0 kW
/ 2.5 kW / 3.0 kW / 3.3 kW / 3.7 kW / 4.0 kW

User Manual

Version 8.0

www.solaxpower.com



©Manual in the QR code of
at www.solaxpower.com

STATEMENT

Copyright

Copyright © SolaX Power Network Technology (Zhejiang) Co., Ltd. All rights reserved.

No part of this manual may be reproduced, transmitted, transcribed, stored in a retrieval system, or translated into any language or computer language, in any form or by any means without the prior written permission of SolaX Power Network Technology (Zhejiang) Co., Ltd.

Trademarks



SOLA X and other symbol or design (brand name, logo) that distinguishes the products or services offered by SolaX has been trademark protected. Any unauthorized use of the above stated trademark may infringe the trademark right.

Notice

Please note that certain products, features, and services mentioned in this document may not be within the scope of your purchase or usage. Unless otherwise specified in the contract, the contents, information, and recommendations presented in this document are provided "as is" by SolaX. We do not provide any warranties, guarantees, or representations, whether express or implied.

The content of the documents is reviewed and updated as needed. However, occasional discrepancies may occur. SolaX retains the right to make improvements or changes in the product(s) and the program(s) described in this manual at any time without prior notice.

The images included in this document are solely for illustrative purposes and may differ based on the specific product models.

For more detailed information, kindly visit the website of SolaX Power Network Technology (Zhejiang) Co., Ltd. at www.solaxpower.com.

SolaX retains all rights for the final explanation.

About This Manual

Scope of Validity

This manual is an integral part of X1-MINI G4 series inverter. It describes the transportation, storage, installation, electrical connection, commissioning, maintenance and troubleshooting of the product. Please read it carefully before operating.

This manual is valid for the following inverter models:

X1-MINI-0.6K-G4	X1-MINI-0.7K-G4	X1-MINI-0.8K-G4
X1-MINI-1.1K-G4	X1-MINI-1.5K-G4	X1-MINI-2.0K-G4
X1-MINI-2.5K-G4	X1-MINI-3.0K-G4	X1-MINI-3.3K-G4
X1-MINI-3.7K-G4	X1-MINI-4.0K-G4	

Model description

X1-MINI-0.6K-G4

1

2

3

Item	Meaning	Description
1	Product family name	"X1-MINI": a type of single phase inverter that supports grid connection of photovoltaic system.
2	Power	"0.6K": rated output power of 0.6 kW.
3	Generation	"G4": the 4 th generation of X1-MINI series



Target Group

The installation, maintenance and grid-related setting can only be performed by qualified personnel who:

- Are licensed and/or satisfy state and local regulations.
- Have good knowledge of this manual and other related documents.

Conventions

The symbols that may be found in this manual are defined as follows.

Symbol	Description
 DANGER	Indicates a hazardous situation which, if not avoided, will result in death or serious injury.
 WARNING	Indicates a hazardous situation which, if not avoided, could result in death or serious injury.
 CAUTION!	Indicates a hazardous situation which, if not avoided, could result in minor or moderate injury, device damage, power generation loss or unanticipated results.
NOTICE!	Provides tips for the optimal operation of the product.

Change History

Changes between document versions are cumulative. The latest version contains all updates made in previous versions.

Version 08 (Sept. 30, 2024)

Updated "[5.2 Scope of Delivery](#)" (Modified PV terminal removal tool to optional)

Version 07 (Nov. 15, 2024)

Updated "[4.1.1 Environment Requirement](#)" (Modified the environment requirements)

Version 06 (Aug. 30, 2024)

Updated "[14 Appendix](#)" (Modified the description of the application of generator, adapter box, and EV charger)

Version 05 (Apr. 3, 2024)

Updated "[13 Technical Data](#)" (Modified Max. PV current and ISC short circuit current)

Version 04 (Dec. 29, 2023)

Updated "[5.2 Scope of Delivery](#)" (Modified items in the packing lists)

Version 03 (Jun. 27, 2023)

Updated "[7.1.1 Terminals of Inverter](#)" (Modified Australian version DC switch)

Version 02 (Mar. 1, 2023)

Updated "[13 Technical Data](#)" (Added 2 model types)

Version 01 (Jan. 3, 2023)

Updated "[13 Technical Data](#)" (Added technical data)

Version 00 (Sept. 27, 2022)

Initial release

Table of Contents

1	Safety	1
1.1	General Safety	1
1.2	Safety Instructions of PV, Inverter and Grid	2
1.2.1	Safety Instructions of PV	2
1.2.2	Safety Instructions of Inverter	3
1.2.3	Safety Instructions of Utility Grid	4
1.3	Additional Safety Instructions	4
2	Product Overview	6
2.1	System Introduction	6
2.2	Appearance	8
2.3	Supported Power Grid	9
2.4	Symbols on the Label and Inverter	10
2.5	Working Principle	11
2.5.1	Circuit Diagram	11
2.6	Working State	12
3	Transportation and Storage	13
4	Preparation before Installation	14
4.1	Selection of Installation Location	14
4.1.1	Environment Requirement	14
4.1.2	Installation Carrier Requirement	17
4.1.3	Clearance Requirement	17
4.2	Tools Requirement	18
4.3	Additionally Required Materials	19
5	Unpacking and Inspection	21
5.1	Unpacking	21
5.2	Scope of Delivery	22
6	Mechanical Installation	23
6.1	Dimensions for mounting	24
6.2	Installation procedures	24
7	Electrical Connection	27
7.1	Overview of Electrical Connection	27
7.1.1	Terminals of Inverter	27
7.1.2	Cable Connections of Inverter	28

7.2	PE Connection	29
7.3	AC Connection.....	32
7.4	PV Connection	35
7.5	COM/CT Port Connection.....	40
7.5.1	RS485 connection.....	40
7.5.2	Meter Connection.....	42
7.5.3	CT Connection	45
7.5.4	DRM Connection	48
7.6	Dongle Port Connection.....	49
8	System Commissioning	52
8.1	Checking before Power-on.....	52
8.2	Powering on the System.....	52
8.3	Lockable DC switch	54
8.4	Checking after Power-on.....	59
8.5	Isolation Fault Alarm.....	59
8.6	Country/Grid Settings.....	59
8.7	Commissioning.....	59
9	Operation on LCD.....	60
9.1	Introduction of Control Panel.....	60
9.2	Introduction of Main Interface.....	61
9.3	Introduction of Menu Interface.....	61
9.3.1	Status.....	62
9.3.2	Language	63
9.3.3	Date&Time.....	64
9.3.4	Setting.....	64
9.3.5	Meter Energy.....	65
9.3.6	Error Logs	65
9.3.7	About.....	65
9.3.8	Grid.....	66
9.3.9	RED.....	67
9.4	Detailed Operation of Settings	67
10	Operation on SolaX App and Web.....	86
10.1	Introduction of SolaXCloud.....	86
10.2	Operation Guide on SolaXCloud App	86
10.2.1	Downloading and installing App.....	86
10.2.2	Operation on the App.....	87
10.3	Operations on SolaXCloud Webpage.....	88
11	Troubleshooting and Maintenance	89

- 11.1 Power off.....89
- 11.2 Troubleshooting.....89
- 11.3 Maintenance.....93
 - 11.3.1 Maintenance routines93
 - 11.3.2 Upgrading Firmware.....94
- 12 Decommissioning..... 96**
 - 12.1 Disassembling the Inverter96
 - 12.2 Packing the Inverter98
 - 12.3 Disposing of the Inverter98
- 13 Technical Data 99**
- 14 Appendix 105**
 - 14.1 Application of Generator.....105
 - 14.1.1 Introduction of generator application105
 - 14.1.2 Notice for generator application105
 - 14.1.3 ATS control.....105
 - 14.2 Application of Adapter Box107
 - 14.2.1 Introduction of Adapter Box application.....107
 - 14.3 Application of Adapter Box G2110
 - 14.3.1 Introduction of Adapter Box G2 application110
 - 14.3.2 Settings for Adapter Box G2.....112
 - 14.4 Application of EV-Charger113
 - 14.4.1 Introduction of EV-Charger application113
 - 14.4.2 Setting for EV-Charger.....114
 - 14.5 Application of Parallel Connection115
 - 14.5.1 Parallel System with Modbus Function.....115

1 Safety

1.1 General Safety

The series inverter has been meticulously designed and thoroughly tested to comply with the relevant state and international safety standards. Nevertheless, like all electrical and electronic equipment, safety precautions must be observed and followed during the installation of the inverter to minimize the risk of personal injury and ensure a safe installation.

Please thoroughly read, comprehend, and strictly adhere to the comprehensive instructions provided in the user manual and any other relevant regulations prior to the installation of the inverter. The safety instructions in this document serve as supplementary guidelines to local laws and regulations.

SolaX shall not be liable for any consequences resulting from the violation of the storage, transportation, installation, and operation regulations outlined in this document. Such consequences include, but are not limited to:

- Inverter damage caused by force majeure events, such as earthquakes, floods, thunderstorms, lightning, fire hazards, volcanic eruptions, and similar events.
- Inverter damage due to human causes.
- Inverter damage caused by strong vibrations from external factors before, during and after installation.
- Usage or operation of the inverter in violation of local policies or regulations.
- Failure to comply with the operation instructions and safety precautions provided with the product and in this document.
- Improper installation or usage of the inverter in unsuitable environmental or electrical conditions.
- Unauthorized modifications to the product or software.
- Inverter damage occurring during transportation by the customer.
- Storage conditions that do not meet the requirements specified in this document.
- Installation and commissioning performed by unauthorized personnel who lack the necessary licenses or do not comply with state and local regulations.

1.2 Safety Instructions of PV, Inverter and Grid

Save these important safety instructions. Failure to follow these safety instructions may result in damage to the inverter and injury or even loss of life.

1.2.1 Safety Instructions of PV

DANGER!

Potential risk of lethal electric shock associated with the photovoltaic (PV) system

- Exposure to sunlight can result in the generation of high DC voltage by PV modules, which can lead to electric shock causing severe injuries or even death.
- Never touch the positive or negative poles of the PV connecting device, and avoid touching both poles simultaneously.
- Do not ground the positive or negative poles of the PV modules.
- Only qualified personnel can perform the wiring of the PV modules.

WARNING!

- Make sure that the input DC voltage does not exceed the maximum DC input voltage specified for the inverter. Overvoltage can cause irreversible damage to the inverter, and such damage is not covered by the warranty.

WARNING!

- PV modules should have an IEC61730 class A or class C rating.

1.2.2 Safety Instructions of Inverter

DANGER!

Potential risk of lethal electric shock associated with the inverter

- Only operate the inverter if it is in a technically faultless condition. Operating a faulty inverter may lead to electric shock or fire.
- Do not attempt to open the enclosure without authorization from SolaX. Unauthorized opening of the enclosure will void the warranty and can result in lethal danger or serious injury due to electric shock.
- Make sure that the inverter is reliably grounded before any operation to prevent the risk of electric shock causing lethal danger or serious injury.
- Only qualified personnel can perform the installation, wiring, maintenance of the inverter by following this document and the related regulations.
- The appliance should not be used by children or persons with reduced physical sensory or mental capabilities, or lack of experience and knowledge unless they have been given supervision or instruction.

WARNING!

- During operation, avoid touching any parts of the inverter other than the DC switch and LCD panel.
- Never connect or disconnect the AC and DC connector while the inverter is running.
- Prior to conducting any maintenance, turn off the AC and DC power and disconnect them from the inverter. Wait for 5 minutes to fully discharge the energy.
- Measure the voltage between terminals UDC+ and UDC- with a multimeter (impedance at least 1 Mohm) to ensure that the device has totally discharged.

WARNING!

- Potential danger of scalding due to the hot enclosure of the inverter
- Avoid touching the inverter while it is running, as it becomes hot during operation and may cause personal injuries.

WARNING!

- Use insulated tools when installing the device, and always wear personal protective equipment during installation and maintenance.

CAUTION!

- Possible damage to health as a result of the effects of radiation! Pregnant women and kids should not stay close to the inverter.

 CAUTION!

- Make sure that children are supervised to prevent them from playing with the inverter.
- Pay attention to the weight of the inverter and handle it properly to avoid personal injuries.

NOTICE!

- Keep all product labels and the nameplate on the inverter clearly visible and well-maintained.

1.2.3 Safety Instructions of Utility Grid

NOTICE!

- Only connect the inverter to the grid with the permission of the local utility grid company.

1.3 Additional Safety Instructions

Surge protection devices (SPDs) for PV installation

 DANGER!

- Over-voltage protection with surge arresters should be provided when the PV power system is installed. The grid connected inverter is fitted with SPDs in both PV input side and MAINS side.
- Please consult professionals before installing SPDs.

Direct or indirect lightning strikes can cause failures. Surge is the main cause of lightning damage to most devices. Surge voltage may occur at photovoltaic input or AC output, especially in remote mountain areas where long distance cable is supplied.

Please consult professionals before installing SPDs.

The external lightning protection device can reduce the influence of direct lightning strike, and the lightning protection device can release surge current to the earth.

If the building installed with external light protection device is far away from the inverter location, in order to protect the inverter from electrical and mechanical damage, the inverter should also install an external lightning protection equipment.

In order to protect DC system, two-stage surge protection equipment is needed between DC cable of inverter and photovoltaic equipment module.

In order to protect the AC system, the level 2 surge protection equipment should be installed at the AC output, located between the inverter and the grid. Installation requirements must comply with IEC61643-21 standard.

All DC cables shall be installed in a distance as short as possible, and the positive and negative cables of the same input need to be bundled together to avoid causing loops in the system. Minimum distance installation and binding requirements also apply to auxiliary grounding and shielding grounding conductors.

Anti-Islanding Effect

The islanding effect means that when the power grid is cut off, the grid-connected power generation system fails to detect the power outage and still supplies power to the power grid. This is very dangerous for the maintenance personnel and the power grid on the transmission line. The inverter's use active frequency offset method to prevent islanding effect.

PE Connection and Leakage Current

All inverter's incorporate a certified internal Residual Current Monitoring (RCM) in order to protect against possible electrocution and fire hazard in case of a malfunction in the PV array, cables or inverter. There are 2 trip thresholds for the RCM as required for certification (IEC 62109-2:2011).

The default value for electrocution protection is 30 mA, and for slow rising current is 300 mA. the house loads. If an external RCD is required by local regulations, it is recommended to choose a Type-A RCD with the rating residual current of 300 mA.



- High leakage current!
- Earth connection essential before connecting supply.

A faulty ground connection can result in equipment failure, personal and death injuries, and electromagnetic interference. Ensure correct according to grounding to IEC62109 and conductor diameter according to STANDARD specification. Do not connect the grounding end of the equipment in series to prevent multi-point grounding. Electrical appliances must be installed in accordance with the wiring rules of each country.

For United Kingdom

The installation that connects the equipment to the supply terminals shall comply with the requirements of BS 7671. Electrical installation of PV system shall comply with requirements of BS 7671 and IEC 60364-7-712. All protective devices cannot be changed.

User shall ensure that equipment is so installed, designed and operated to maintain at all times compliance with the requirements of ESQCR22(1)(a).

2 Product Overview

2.1 System Introduction

The X1-MINI G4 series inverter is a transformerless single-phase PV grid-connected inverter which is designed to convert the direct current power generated from the PV modules into grid-compatible AC current and feeds the AC current to the utility grid. It supports various intelligent solutions such as load management, wireless metering, etc. to achieve efficient and economical energy utilization.

Table 2-1 System item description

Item	Description
X1-MINI G4 series (the device covered in this manual)	The X1-MINI G4 series is a grid-connected inverter that supports grid connection of a photovoltaic system.
PV modules	PV modules work in MPPT mode. The maximum number of MPPT is one for X1-MINI G4 inverters.
Meter/CT	The meter/CT is used by the inverter for import / export or consumption readings. Wireless meter solution is supported.
Adapter Box G2 (supported)	With SolaX Adapter Box G2, you can connect the smart heat pump to the photovoltaic systems, realizing the control of the heat pump through inverter. Please refer to " 14.3 Application of Adapter Box G2 " for specific wiring and setting.
DataHub (supported)	SolaX DataHub is a professional device that for monitoring platforms of photovoltaic power generation systems, which enables data collection, storage, output control, centralized monitoring, and centralized maintenance of devices such as inverters, electricity meters, and environmental monitoring instruments in photovoltaic power generation systems. Please refer to " 14.5.2 Parallel system with DataHub " for specific wiring and setting.
EV-Charger (supported)	The series inverter can communicate with SolaX EV-Charger to form an intelligent photovoltaic and EV charging energy system, thus maximizing the utilization of photovoltaic energy. Please refer to " 14.4 Application of EV-Charger " for specific wiring and setting.

Item	Description
Generator (supported)	SolaX PV-Genset solution ensures optimum interaction between the photovoltaics and diesel generator, which saves fuel, lowers energy costs and ensures a stable and reliable power supply. Please refer to "14.1 Application of Generator" for specific wiring and setting.
Grid	220 V / 230 V and 240 V grid are supported.
SolaXCloud	SolaXCloud is an intelligent, multifunctional monitoring platform that can be accessed either remotely or through a hard wired connection. With the SolaXCloud, the operators and installers can always view key and up to date data.

System Overview

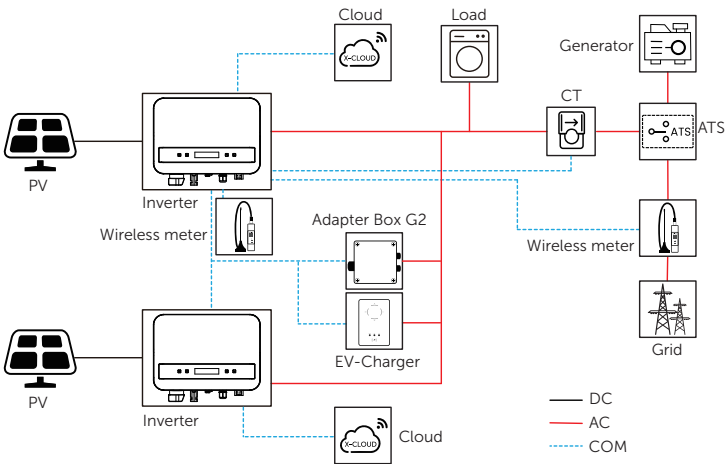

Figure 2-1 System overview diagram 1

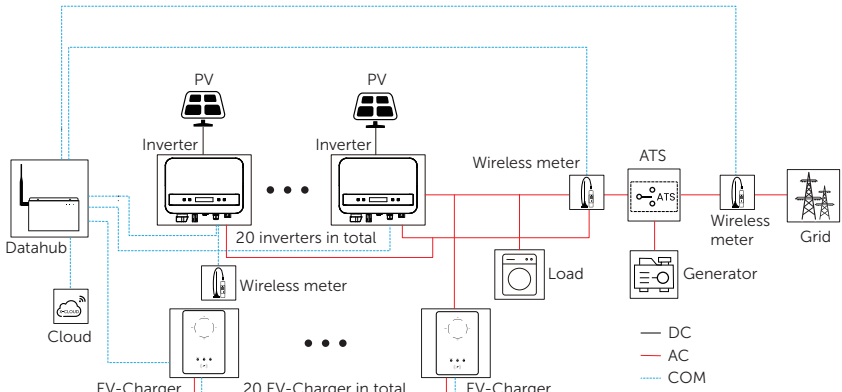

Figure 2-2 System overview diagram 2

NOTICE!

- The parallel system with Modbus Function, the parallel system with Datahub and the EV-Charger application can not be realised at the same time, choose only one of these applications at a time.

2.2 Appearance

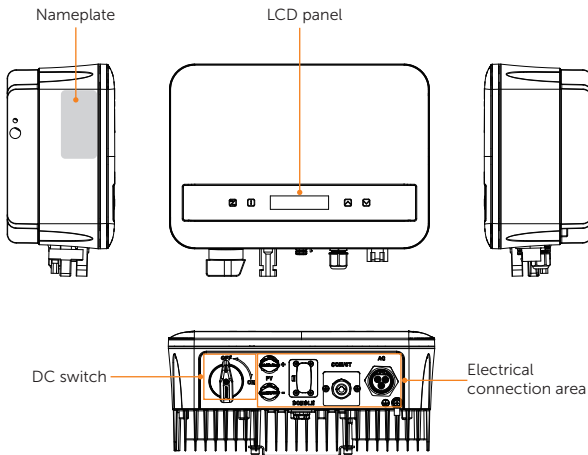

Figure 2-1 Appearance

Table 2-1 Description of appearance

Item	Description
Nameplate	Nameplate clearly identifies the device type, serial number, specific DC / AC parameters, certification, etc.
LCD panel	Including screen, indicators and keys. Screen displays the information; indicators indicate the status of inverter. Keys are used to perform the parameter setting.
DC switch	Disconnect the PV input when necessary.
Electrical connection area	Including PV terminals, AC terminal, communication terminal, etc.

2.3 Supported Power Grid

There are different ways of wiring for different grid systems. TT / TN-S / TN-C-S are shown as below:

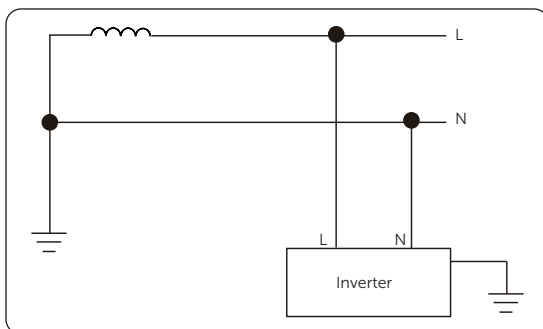

Figure 2-2 Supported power grid-TT

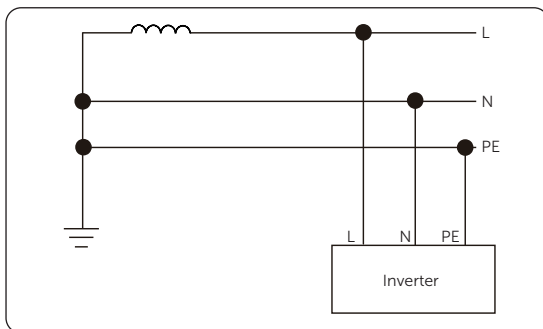

Figure 2-3 Supported power grid-TN-S

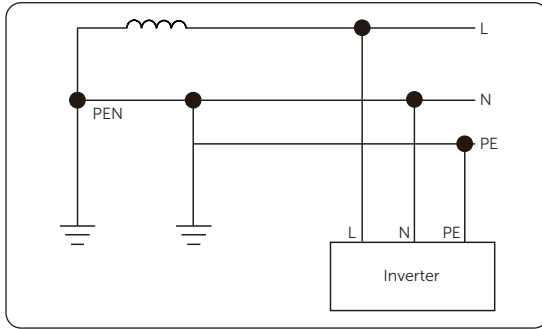













Figure 2-4 Supported power grid-TN-C-S

2.4 Symbols on the Label and Inverter

Table 2-2 Description of symbols

Symbol	Description
	CE mark. The inverter complies with the requirements of the applicable CE guidelines.
	TUV certified.
	RCM mark. The inverter complies with the requirements of the applicable RCM guidelines.
	Additional grounding point.
	Beware of hot surface. Do not touch a running inverter, as the inverter becomes hot during operation!
	Risk of electric shock. High voltage exists after the inverter is powered on!
	Risk of danger. Potential hazards exist after the inverter is powered on!
	Read the enclosed documentations.

Symbol	Description
	Do not dispose of the inverter together with household waste.
	Do not operate this inverter until it is isolated from mains and on-site PV generation source.
 	Danger of high voltage. Do not touch live parts for 5 minutes after disconnection from the power sources.

2.5 Working Principle

2.5.1 Circuit Diagram

The inverter is equipped with single-channel MPPT for DC input to ensure maximum power even under different photovoltaic input conditions. The inverter unit converts direct current into alternating current that meets the requirements of the power grid and feeds it into the power grid. The principle design of inverter is shown in the figure below:

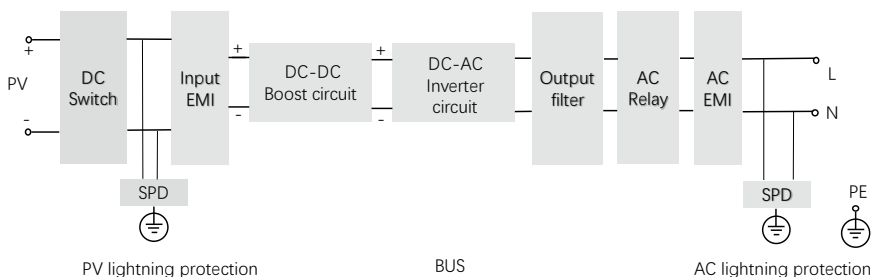

Figure 2-5 Circuit diagram for X1-MINI G4 series inverter

2.6 Working State

The series inverter has Waiting, Checking, and Normal states.

Table 2-3 Description of working state

State	Description
Waiting	<ul style="list-style-type: none">The inverter is waiting to check when the DC input voltage from panels is greater than the start-up voltage but less than the lowest operating voltage. When the inverter with auxiliary power supply lacks PV, the screen also shows Waiting.
Checking	<ul style="list-style-type: none">Inverter will check DC input environment automatically when DC input voltage from the PV panels exceeds the lowest operating voltage and PV panels have enough energy to start inverter.
Normal	<ul style="list-style-type: none">Inverter begins to operate normally when the blue light is constantly on.Meanwhile feedback energy to grid (if condition permits), LCD displays the present output power.

3 Transportation and Storage

If the inverter is not put into use immediately, the transportation and storage requirements need to be met:

Transportation

- The inverter must be transported in its original packaging. SolaX will not be held responsible for any damage to the inverter caused by improper transportation or by transportation after it has been installed.
- Observe the caution signs on the packaging of inverter before transportation.
- Pay attention to the weight of the inverter. Carry the inverters by the required number of personnel as specified by local regulations.(gross weight of X1-MINI G4: 5.5 kg)
- Wear protective gloves when carrying the equipment by hand to prevent injuries.
- When lifting up the inverter, hold the bottom position of the carton. Keep the inverter horizontal in case of falling down.

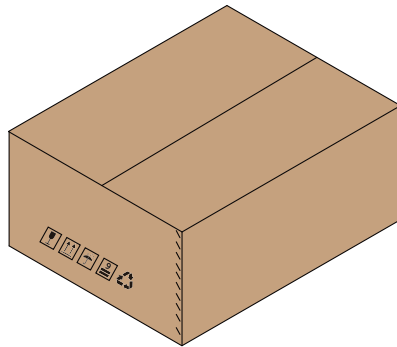

Figure 3-1 Caution signs on the packaging

Storage

- The inverter must be stored indoors.
- Do not remove the original packaging material and check the outer packaging material regularly.
- The storage temperature should be between -25°C and $+60^{\circ}\text{C}$. The relative humidity should be between 60%RH and 65%RH.
- Stack the inverter in accordance with the caution signs on the inverter carton to prevent their falling down and device damage. Do not place it upside down.

4 Preparation before Installation

4.1 Selection of Installation Location

The installation location selected for the inverter is quite critical in the aspect of the guarantee of machine safety, service life and performance. It has the IP66 ingress protection, which allows it to be installed outdoor. The installation position shall be convenient for wiring connection, operation and maintenance.

4.1.1 Environment Requirement

Make sure the installation environment meets the following conditions:

- The ambient temperature: -25°C to $+60^{\circ}\text{C}$.
- The relative humidity shall be between 0-100%RH.
- Do not install the inverter in the areas where the altitude exceeds 3000 m.
- Install the inverter in a well-ventilated environment for heat dissipation. It is recommended to install an awning over the inverter if it is installed on a support outdoor.
- Do not install the inverter in areas with flammable, explosive and corrosive materials or near antennas.
- Avoid direct sunlight, rain exposure and snow accumulation.

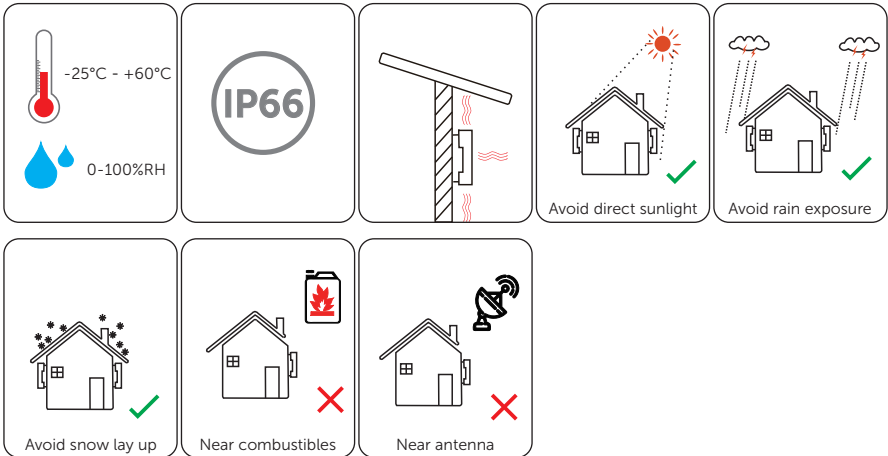

NOTICE

- For outdoor-installation, precautions against direct sunlight, rain exposure and snow accumulation are recommended.
 - Exposure to direct sunlight raises the temperature inside the device. This temperature rise poses no safety risks, but may impact the device-performance.
-
- Install the inverter at least 500 meters away from the coast and avoid sea breeze directly hit.

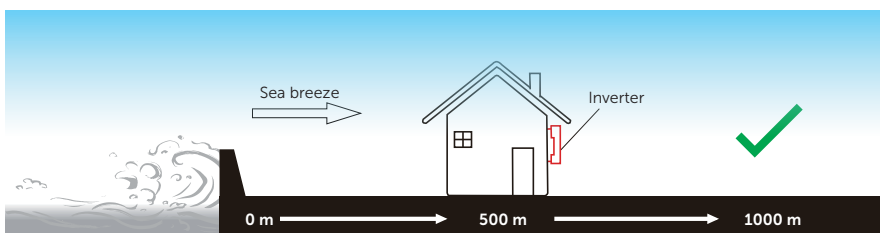

Figure 4-1 Recommended installation position

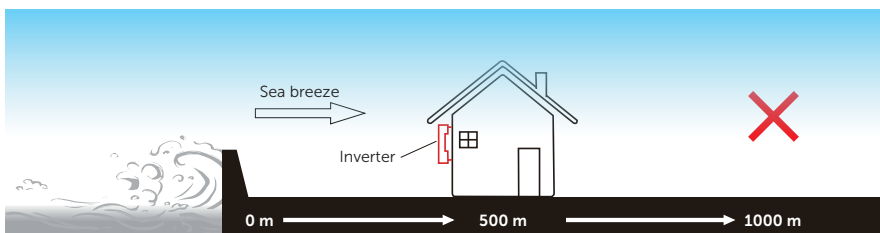

Figure 4-2 Incorrect installation position

NOTICE!

- For the installation of the whole system, please refer to the specific environment requirement of each unit.

4.1.2 Installation Carrier Requirement

The installation carrier must be made of a non-flammable material, such as solid brick, concrete, etc. and be capable of supporting the weight of the inverter and suitable of the dimensions of the inverter. If the wall strength is not enough (such as wooden wall, the wall covered by a thick layer of decoration), it must be strengthened additionally.

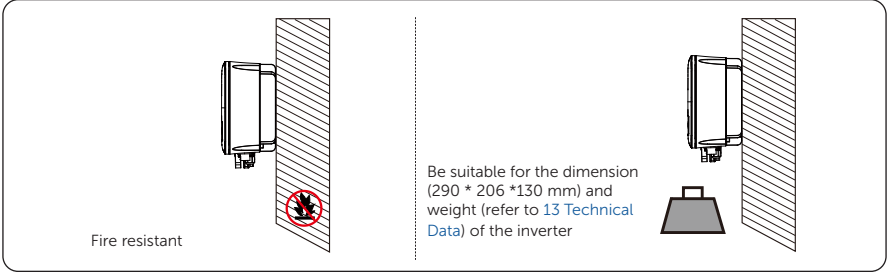

Figure 4-3 Installation carrier requirement

4.1.3 Clearance Requirement

The minimum clearance reserved for the connected terminal at the bottom of inverter should be 15 cm (if users have to use Pocket WiFi+4G). When planning installation space, it is important to consider the bending radius of the wires.

To guarantee proper heat dissipation and ease of disassembly, the minimum space around the inverter must meet the standards indicated below.

For installations with multiple inverters, make sure to leave a minimum space of 30 cm between each inverter. In areas with high ambient temperatures, increase the clearances between the inverters and provide adequate fresh air ventilation if feasible.

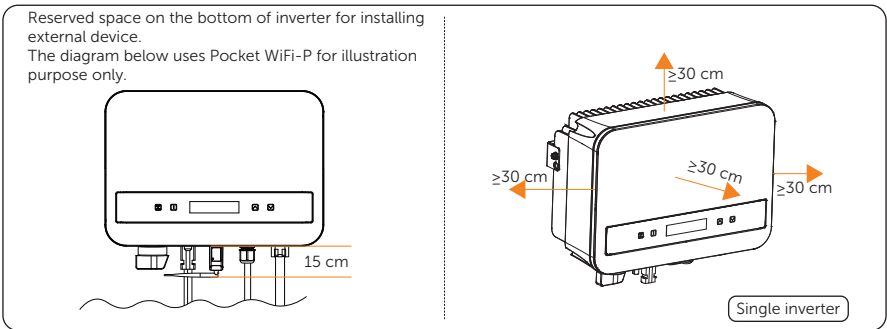

Figure 4-4 Clearance requirement for single inverter

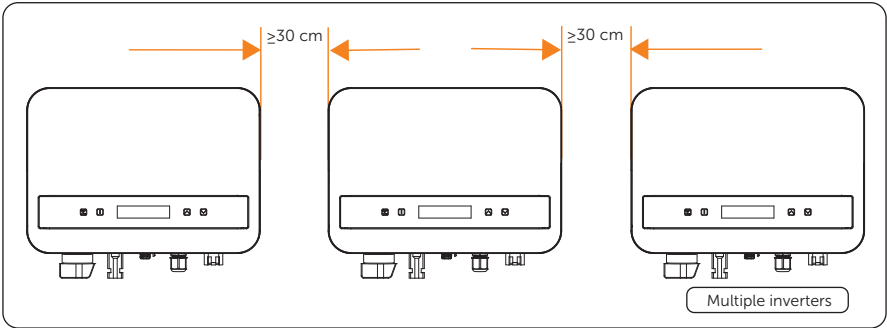
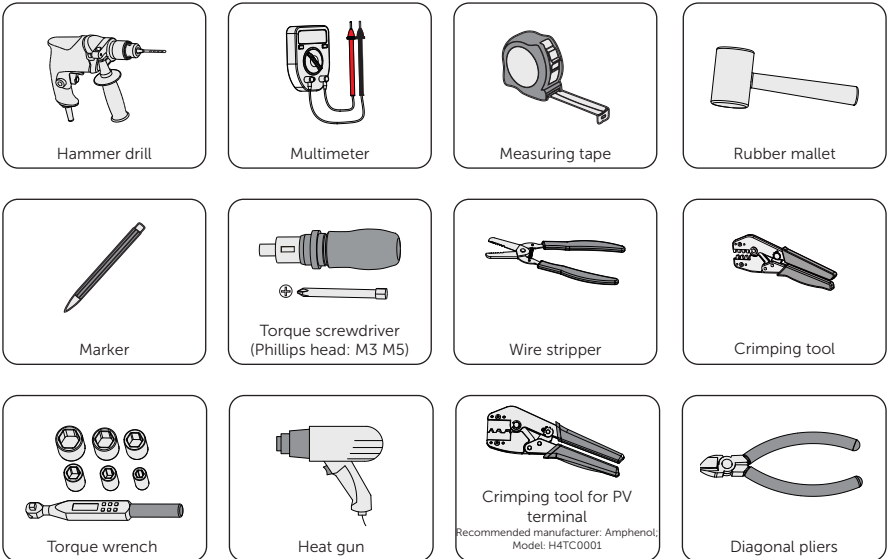
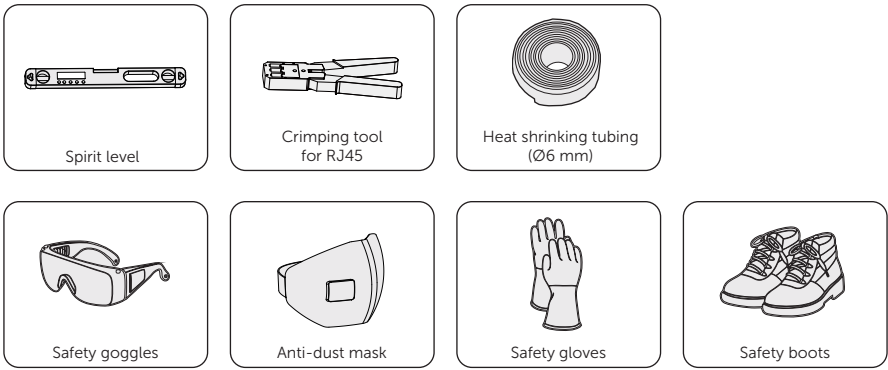

Figure 4-5 Clearance requirement for multiple inverters

4.2 Tools Requirement

Installation tools include but are not limited to the following recommended ones. If necessary, use other auxiliary tools on site. Please note that the tools used must comply with local regulations.





4.3 Additionally Required Materials

Table 4-1 Additionally required wires





No.	Required Material	Type	Conductor Cross-section
1	PV cable 	Dedicated PV wire withstand voltage 600 V	4~6 mm ²
2	AC cable 	Three-core copper wire	2.5~6 mm ² (0.6 K-3.3 K); 3~6 mm ² (3.7 K-4.0 K) Outer diameter: Ø6~15 mm
3	Communication cable 	Network cable CAT5	0.2 mm ² Outer diameter: Ø2~6 mm
4	Additional PE cable 	Conventional yellow and green wire	2.5~6 mm ² (0.6 K-3.3 K); 3~6 mm ² (3.7 K-4.0 K) * The cross-sectional area of PE line should be the same as that of L/N line.

Table 4-2 Circuit breaker recommended

Model	X1-MINI-0.6K-G4	X1-MINI-0.7K-G4	X1-MINI-1.1K-G4	X1-MINI-1.5K-G4	X1-MINI-2.0K-G4
Circuit breaker 	10 A	10 A	10 A	10 A	16 A
Model	X1-MINI-2.5K-G4	X1-MINI-3.0K-G4	X1-MINI-3.3K-G4	X1-MINI-3.7K-G4	X1-MINI-4.0K-G4
Circuit breaker 	20 A	20 A	20 A	25 A	25 A

5 Unpacking and Inspection

5.1 Unpacking

- The inverter undergoes 100% testing and inspection before delivery. However, damages may still occur during transportation. Before unpacking, please carefully check the external packaging for any signs of damage, such as punctures or cracks.
- Unpacking the inverter according to the following figure.

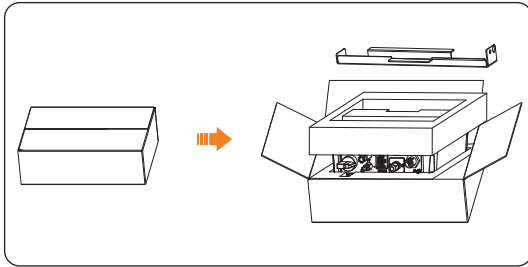
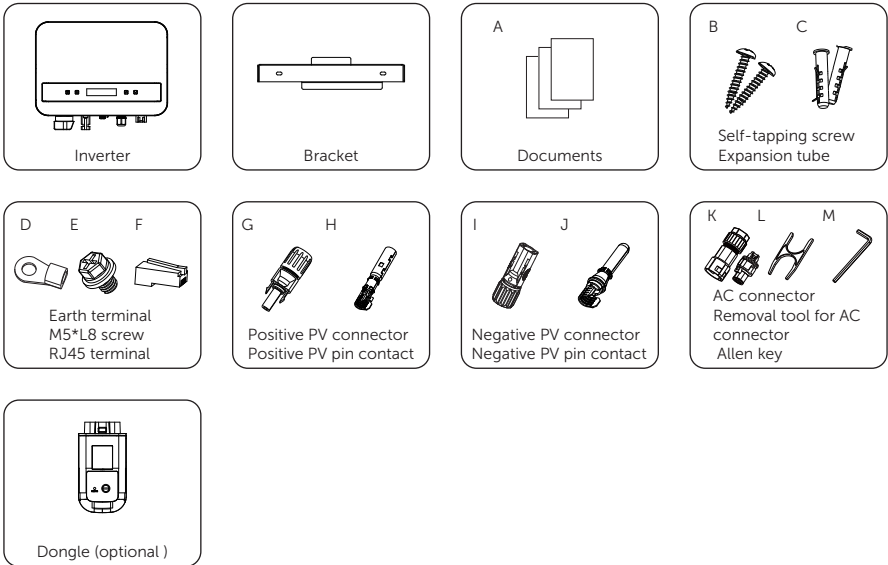

Figure 5-1 Unpacking the inverter

- Properly handle all the packaging materials in case they may be reused for storage and transportation of the inverter in the future.
- Upon opening the package, check whether the inverter is intact and whether all accessories are included. If any damage is found or any parts are missing, contact your dealer immediately.

5.2 Scope of Delivery



*Refer to the actual delivery for the optional accessories.

Table 5-1 Packing list

Item No.	Items	Quantity	Remark
/	Inverter	1 pc	
/	Bracket	1 pc	
A	Documents	/	
B	Self-tapping screw	2 pcs	For bracket installation
C	Expansion tube	2 pcs	For bracket installation
D	Earth terminal	1 pc	For PE line connection
E	M5*L8 screw	1 pc	For securing inverter on the bracket
F	RJ45 terminal	1 pc	
G	Positive PV connector	1 pc	
H	Positive PV pin contact	1 pc	
I	Negative PV connector	1 pc	
J	Negative PV pin contact	1 pc	
K	AC connector	1 pc	For COM connection
L	Removal tool for AC connector	1 pc	For removing AC connector
M	Allen key	1 pc	
/	Dongle (optional)	/	

6 Mechanical Installation

WARNING!

- Only qualified personnel are allowed to perform the mechanical installation in accordance with local laws and regulations.
- Check the existing power cables or other piping in the wall to prevent electric shock or other damage.
- Use insulated tools and wear personal protective equipment throughout the installation and maintenance process.

CAUTION!

- During installation, always be cautious about the weight of the inverter. Improper lifting or dropping of the inverter may result in personal injury.

NOTICE!

- Install the inverter at a maximum back tilt of 5 degrees and avoid it being forward tilted, side tilted, or upside down.

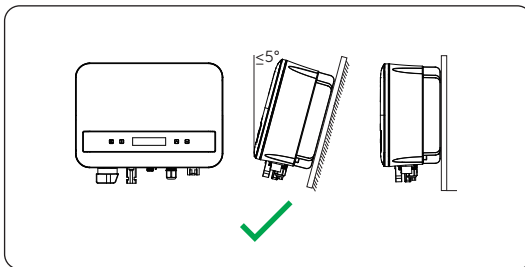

Figure 6-1 Correct installation

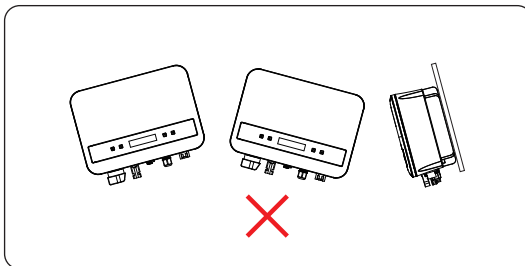

Figure 6-2 Incorrect installation

6.1 Dimensions for mounting

Before installation, check the dimensions of the wall mounting bracket and ensure that enough space is reserved for the installation and heat dissipation of the entire system.

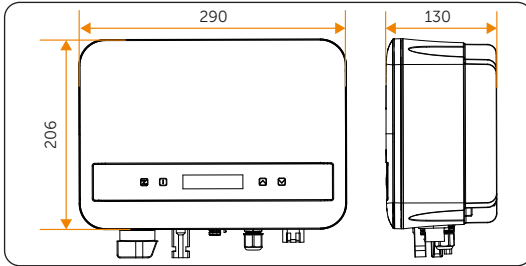

Figure 6-3 Dimensions 1 (Unit: mm)

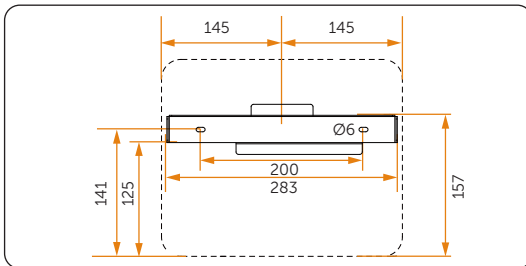

Figure 6-4 Dimensions 2 (Unit: mm)

6.2 Installation procedures

Step 1: Horizontally align the bracket with the wall, adjust the position of the bracket with a spirit level until the bubble stays in the middle, and then mark holes.

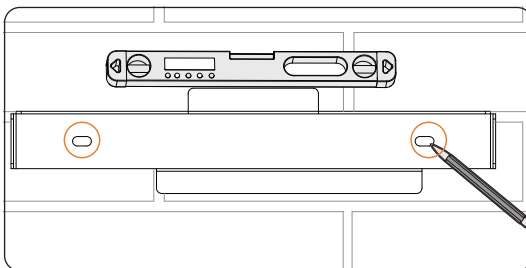

Figure 6-5 Marking the holes

Step 2: Set the bracket aside and drill holes with $\varnothing 6$ drill bit. The depth of the holes should be 50 mm. Knock the expansion tubes (part C) into the holes.

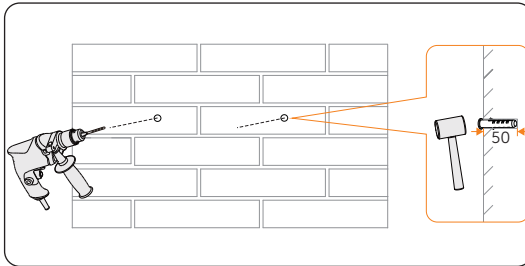

Figure 6-6 Drilling holes (Unit: mm)

Step 3: Attach the bracket on the wall again. Use a screwdriver to secure the bracket by tightening screws into the expansion tubes.

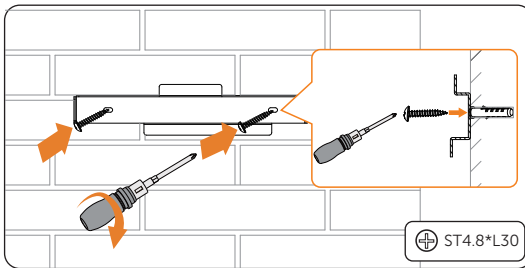

Figure 6-7 Securing the wall mounting bracket

Step 4: Hang the inverter over the bracket, move the inverter close to it, slightly lay down the inverter, and make sure the mounting bar on the back are fixed well with the groove on the bracket. If the inverter needs to be temporarily placed on the ground, use foam or other protective materials to protect it against potential damages.

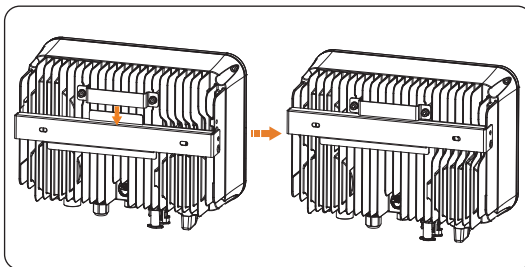

Figure 6-8 Mounting the inverter

Step 5: Use M5*L8 screw (part E) to secure the inverter on the left side.

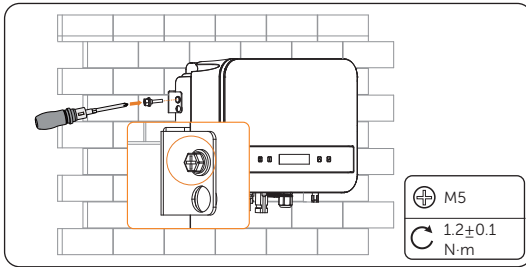

Figure 6-9 Securing the inverter

7 Electrical Connection

DANGER!

- Before electrical connection, make sure the DC switch and AC breaker are disconnected. Otherwise, the high voltage may cause electric shock, resulting in severe personal injuries or even death.

WARNING!

- Only qualified personnel are allowed to perform the electrical connection following local laws and regulations.
- Strictly follow the instructions of this manual or other related documentation for electrical connection. Inverter damages caused by incorrect wiring are not covered by the warranty.
- Use insulated tools and wear personal protective equipment throughout the electrical connection process.

7.1 Overview of Electrical Connection

7.1.1 Terminals of Inverter

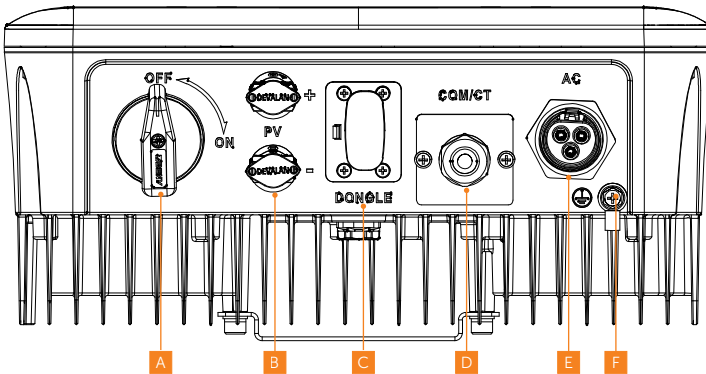

Figure 7-1 Terminals of Inverter

Table 7-1 Description of terminals

Item	Description	Remarks	Decisive voltage class
A	DC switch (optional)	Refer to "8.3 Lockable DC switch"	
B	DC input terminal		DVC-C
C	Dongle		DVC-A
D	COM/CT		DVC-A
E	AC output terminal		DVC-C
F	Ground terminal		

7.1.2 Cable Connections of Inverter

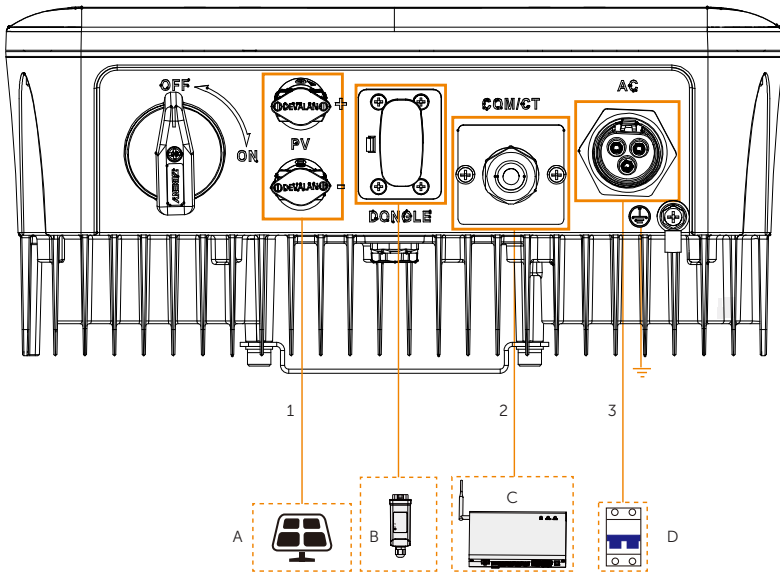

Figure 7-2 Cable connections of inverter

Table 7-2 Descriptions of connected part

Item	Part	Description	Source
A	PV module	A PV string is composed of the PV modules connected in series.	Prepared by user

Item	Part	Description	Source
B	(Optional) SolaX dongle	SolaX Pocket series dongle like Pocket WiFi V4.0, Pocket WiFi+4G, etc.	Purchased from SolaX
C	(Optional) SolaX communication device	SolaX DataHub, Adapter Box G2 and EV-Charger are supported. Select the device as needed.	Purchased from SolaX
D	AC switch	Select an appropriate AC switch according to the local regulations to ensure the inverter can be securely disconnected from the grid when an emergency occurs. Refer to "4.3 Additionally Required Materials" for the recommended specifications of AC switch.	Prepared by user

Table 7-3 Descriptions of cables

Item	Cable	Type and specifications	Source
1	DC input power cable		Prepared by user
2	RS485 communication cable	Refer to "4.3 Additionally Required Materials".	Prepared by user
3	AC output cable		Prepared by user

7.2 PE Connection

The inverter must be reliably grounded. The PE connection point has been marked with . It is recommended to connect the inverter to a nearby grounding point.

NOTICE!

- X1-MINI G4 series supports the earthing detection function. Before startup, the inverter will detect whether it has been properly grounded. If **Earth Detect** is enabled, PE cable of AC line or PE line is not grounded, the inverter will turn on the red light and report **Earth Fault**.

PE connection procedures

Step 1: Strip the insulation of the PE cable to an appropriate length.

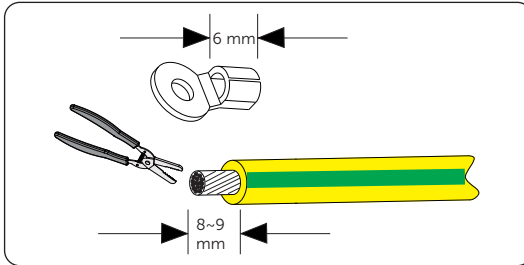

Figure 7-3 Stripping the PE cable

Step 2: Pull the heat-shrink tubing over the PE cable and insert the stripped section into the earth terminal (part D).

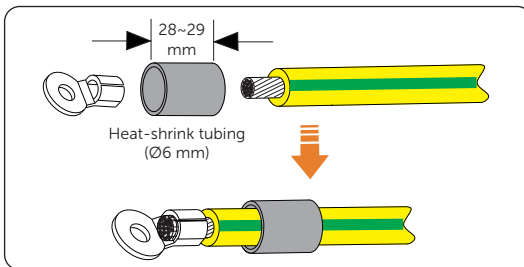

Figure 7-4 Installing the tubing and OT terminal

Step 3: Crimp it with crimping tool, pull the heat-shrink tubing over the stripped section of the earth terminal and use a heat gun to shrink it so that it can be firmly contacted with the terminal.

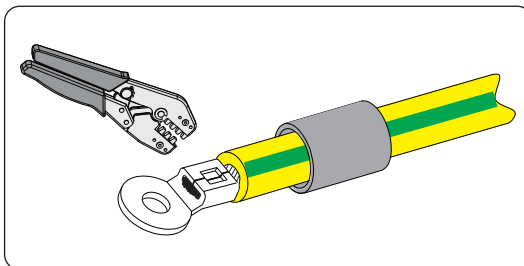

Figure 7-5 Crimping the cable

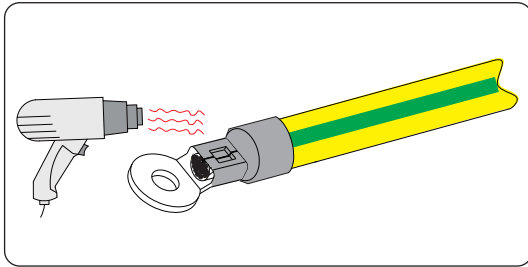

Figure 7-6 Shrinking the tubing

Step 4: Remove the PE screw on the inverter with cross screwdriver.

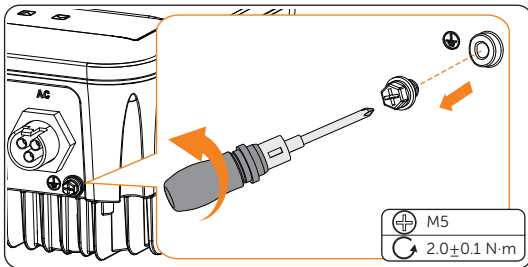

Figure 7-7 Uninstalling the screw

Step 5: Connect the assembled PE cable to the grounding point of the inverter, and secure it with the original screw. (Torque: 2.0±0.1 N-m)

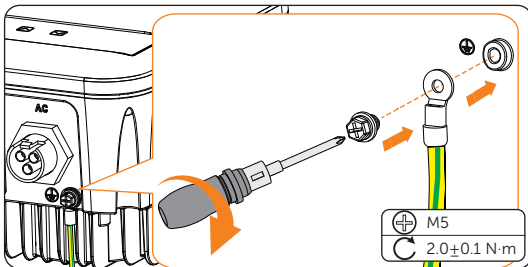

Figure 7-8 Securing the PE cable

7.3 AC Connection

NOTICE!

- Before connecting the inverter to the grid, approval must be received by local utility as required by national and state interconnection regulations.

Requirements for AC connection

- Grid voltage requirement
 - » The grid voltage must be within the permissible range. The inverter is suitable for rated voltage 220/230/240 V, frequency 50/60 Hz. Other technical requests should comply with the requirement of the local public grid.
- Residual Current Device (RCD)
 - » The inverter has an integrated Type-B Residual Current Monitoring Unit (RCMU). The inverter does not require an external residual-current device when operating. If an external RCD is required by local regulations, it is recommended to use a Type-A RCD with the value of 300 mA.
- AC breaker
 - » An AC breaker that matches the power of the inverter must be connected between the inverter output and the power grid, and each inverter must be equipped with an independent breaker or other load disconnection unit to ensure the safe disconnection from the grid. For specific information on the AC breaker for Grid, refer to "[4.3 Additionally Required Materials](#)".
- Load
 - » It is prohibited to connect any load between the inverter and the AC breaker.

Table 7-4 Cable and micro-breaker recommended

Item	X1-MINI- 0.6K/0.7K /1.1K/1.5K-G4	X1-MINI- 2.0K-G4	X1-MINI-2.5K /3.0K/3.3K-G4	X1-MINI- 3.7K/4.0K-G4
L, N cable	2.5-6 mm ²	2.5-6 mm ²	2.5-6 mm ²	3-6 mm ²
PE cable	2.5-6 mm ²	2.5-6 mm ²	2.5-6 mm ²	3-6 mm ²
Micro-breaker	10 A	16 A	20 A	25 A

NOTICE!

- Copper cable is recommended, if you use aluminum cable, please consult the inverter manufacturer.
- The parameter varies because of different environment and material.
- The cross-sectional area of PE line should be the same as that of L/N line.
- Please choose appropriate cable and micro-breaker according to the local laws and regulations.

Wiring procedures

! DANGER!

- Check the grid voltage and compare with the permissive voltage range (refer to "13 Technical Data").
- Disconnect the circuit-breaker from all the phases and secure against re-connection.

Step 1: Strip L and N wires to 52.5 mm and the PE wire to 55 mm. Use the crimping pliers to strip 6 mm of insulation from all wire ends as below.

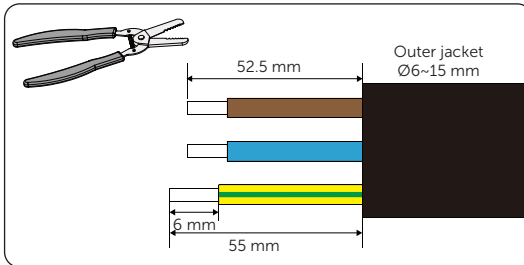

Figure 7-9 Strip the L, N, PE wires

Step 2: The AC connector (part J) provided in the packing list includes A and B. Separate A into component 1 and component 2.

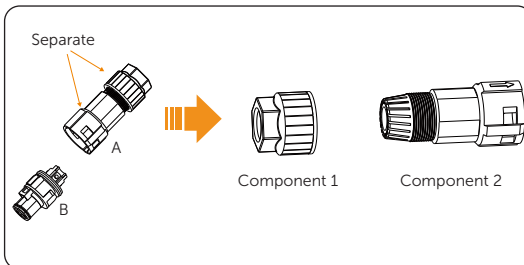

Figure 7-10 Separate component A

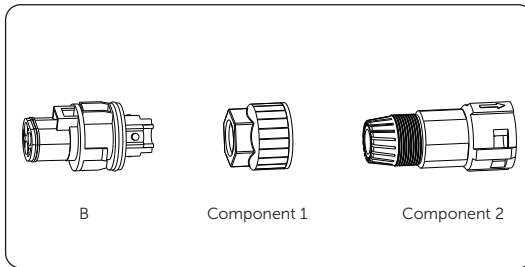

Figure 7-11 Separated AC connector

Step 3: Slide the component 1 and component 2 onto the AC cable.

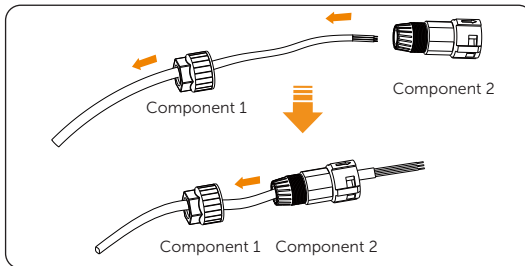

Figure 7-12 Slide component 1&2 on to AC cable

Step 4: Insert the stripped end of L, N and PE wires into the corresponding hole in the B, and then tight each screw (to tight each wire in place). (Allen key (part L); Torque: 0.5 ± 0.1 N·m).

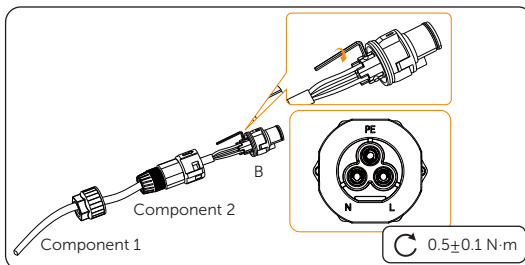

Figure 7-13 Insert wires in to the corresponding holes

Step 5: Tighten A with component 2. Screw down the component 1 tightly. (torque: 3 ± 0.3 N·m)

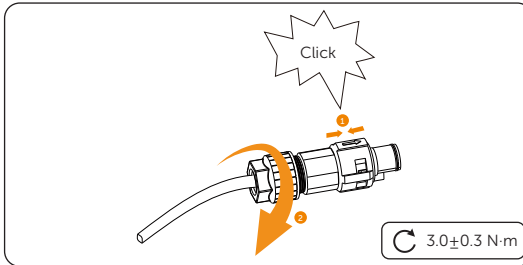

Figure 7-14 Screw down component 1

Step 6: Connect the AC plug to the inverter.

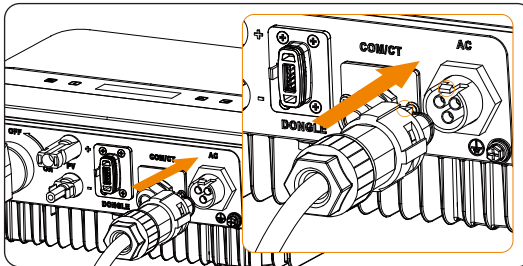

Figure 7-15 Connect AC plug to the inverter

NOTICE!

- Make sure that the buckles are on the same side.

7.4 PV Connection

! DANGER!

- When exposed to the sunlight, PV modules will generate lethal high voltage. Please take precautions.
- Before connecting the PV modules, make sure that both DC switch and AC breaker are disconnected, and that the PV module output is securely isolated from the ground.

WARNING!

- To mitigate the risk of fire, it is crucial to utilize a dedicated crimping tool specifically designed for PV installations to ensure secure and reliable connections.

CAUTION!

- Power is fed from more than one source and more than one live circuit.
- In order to save cable and reduce the DC loss, we suggest installing the inverter near PV modules.

Requirements for PV connection

- Open circuit voltage and operating voltage
 - » The open circuit voltage of each module array cannot exceed the maximum PV input voltage (refer to "13 Technical Data") of the inverter. Otherwise, the inverter may be damaged.
 - » The operating voltage of PV modules must be within the MPPT voltage range (refer to "13 Technical Data") of the inverter. If the operating voltage of PV modules exceeds the MPPT voltage range, the inverter will prompt a **BusVoltFault** alarm. Consider the impact of low temperature on the voltage of the photovoltaic panels, as lower temperatures tend to result in higher voltages.

Table 7-5 Max. DC voltage limitation

Model	X1-MINI- 0.6K/0.7K/0.8K/1.1K/1.5K/2.0K -G4	X1-MINI- 2.5K/3.0K/3.3K/3.7K/4.0K-G4
Max. DC voltage (V)	450	550

- PV module
 - » The PV modules within the same MPPT channel are of the same brand. Additionally, the strings within the same channel should have identical quantities, and be aligned and tilted identically.
 - » The positive or negative pole of the PV modules should not be grounded.
 - » The positive cables of the PV modules must be connected with positive DC connectors.
 - » The negative cables of the PV modules must be connected with negative DC connectors.

Wiring procedures

- Step 1:** Make sure that the DC switch is off, then choose 4-6 mm² wire to connect the PV module.
- Step 2:** Strip 7 mm of insulation from the wire end by using the wire stripper crimping tool.

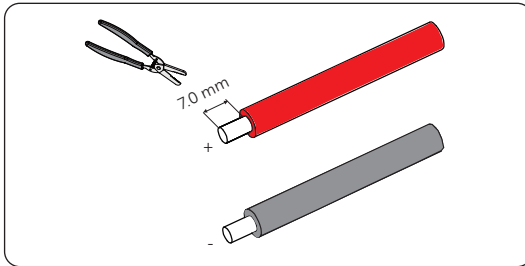

Figure 7-16 Stripping the PV cable

NOTICE!

- MC4 crimping tool recommended: model : H4TC0001; manufacturer: Amphenol

- Step 3:** Insert striped wire into pin contact (part G and I) and ensure all conductor strands are captured in the pin contact.

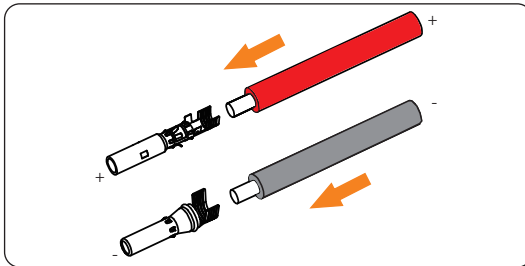

Figure 7-17 Inserting the PV pin contact

- Step 4:** Make sure the the PV cable and PV pin contact (part E) are of the same polarity. Crimp it with crimping tool for PV terminal. Pay attention to the crimping position.

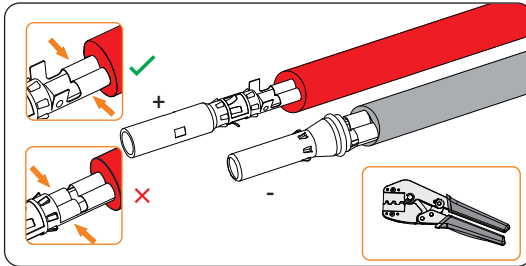

Figure 7-18 Crimping the terminal

- Step 5:** Separate the DC connector (part F and H) as two parts: the plug and the cable nut. Insert the wire into plug forcibly, when a "Click" is heard or felt, the pin contact assembly is seated correctly.

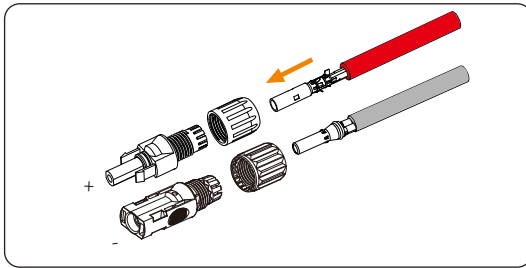

Figure 7-19 Threading the PV cable

- Step 6:** A "Click" will be heard if it is connected correctly. Gently pull the cable backward to ensure firm connection. Tighten the swivel nut clockwise. Verify that the PV connectors have the correct polarity before connection.

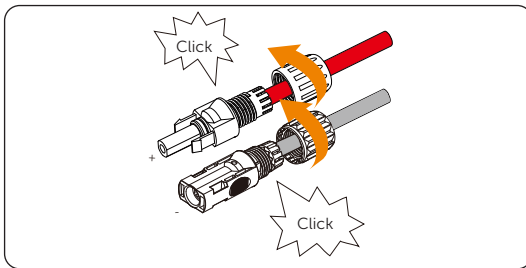

Figure 7-20 Securing the PV cable

Step 7: Use a voltage measuring device which complies with the local regulation to measure the positive and negative voltage of the assembled PV connectors. Make sure the open circuit voltage does not exceed the Max. DC voltage (refer to "13 Technical Data").

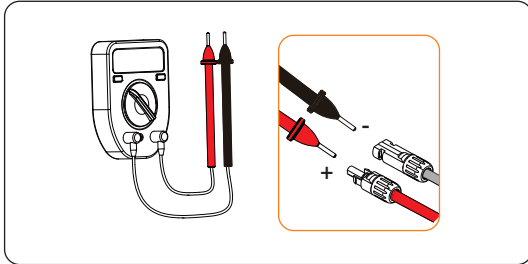

Figure 7-21 Measuring the voltage of PV connectors

NOTICE!

- If the voltage reading is negative, it indicates an incorrect DC input polarity. Please check if the wiring connections on the measuring device are correct or PV connectors are not mistakenly connected.

Step 8: Remove the PV terminal caps.

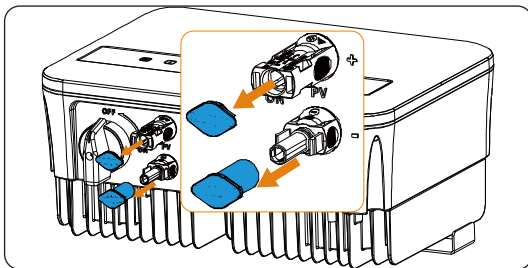

Figure 7-22 Remove the PV terminal caps

NOTICE!

- Skip Step 8 if the inverter is not equipped with the PV terminal caps.

- Step 9:** Connect the assembled PV connectors to the corresponding terminals until there is an audible “Click”. The PV+ on the string side must be connected to the PV+ on the inverter side, and the PV– on the string side must be connected to the PV– on the inverter side.

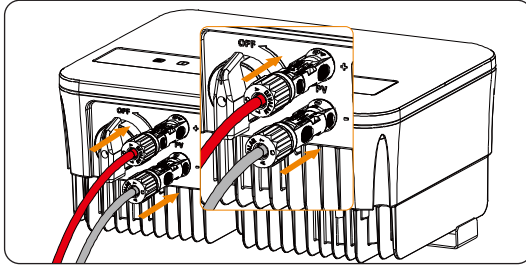

Figure 7-23 Connecting the PV cable

! WARNING!

- Seal the unused PV terminals with the original terminal caps. If all PV terminals are connected, keep the waterproof caps in a safe place. Reinstall them immediately after removing the connectors from the terminals.

7.5 COM/CT Port Connection

The inverter provides a COM/CT port, through this port the inverter can communicate with a computer, Datahub, meter, CT or other devices to achieve various functions.

7.5.1 RS485 connection

RS485 is one standard communication interface which can transmit the real-time data from inverter to PC or other monitoring equipment.

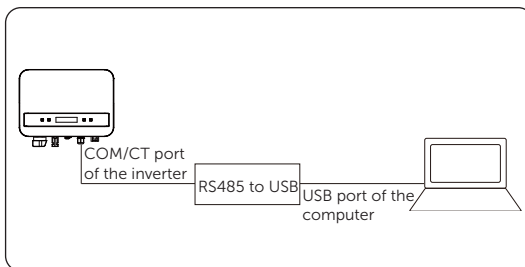

Figure 7-24 RS485 connection

Table 7-6 PIN definition of RS485

PIN	1	2	3	4	5	6	7	8
Definition	X	X	X	485_A	485_B	X	X	X

RS485 connection wiring procedure

Step 1: Firstly unscrew the screw from the COM/CT port. (PH1 cross screwdriver. Torque: $1.0 \pm 0.1 \text{ N}\cdot\text{m}$)

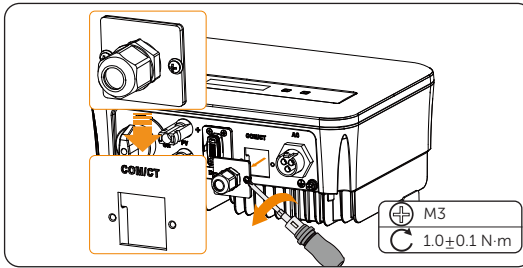

Figure 7-25 Disassemble COM/CT port

Step 2: Prepare a communication cable and strip 10~15 mm of the insulation part. Thread the communication cable through the waterproof connector, then insert it into the RJ45 terminal (part E) following the PIN definition rule.

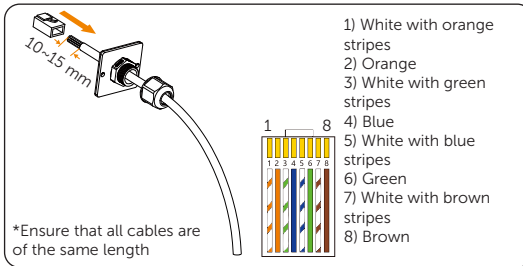

Figure 7-26 Insert the communication cable

Step 3: Crimp the RJ45 terminal with the crimping tool for RJ45.

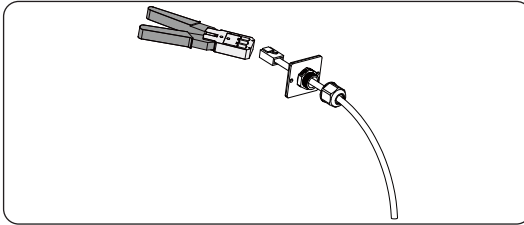

Figure 7-27 Crimp the RJ45 terminal

Step 4: Insert the RJ45 terminal into the COM/CT port of the inverter, screw down the screw on the port and tighten the waterproof connector.

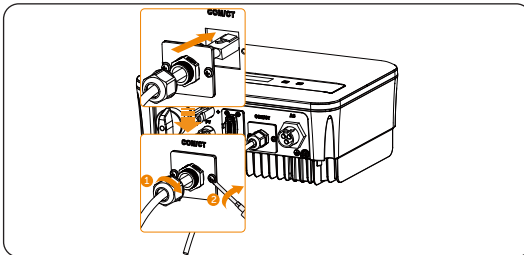

Figure 7-28 Insert the terminal into COM/CT port

7.5.2 Meter Connection

The inverter should work with an electric meter or current transformer (CT for short) to monitor household electricity usage. The electricity meter can transmit the relevant electricity data to the inverter or platform. And this series of inverter also support wireless meter plan.

With this single phase meter working together with the inverter, you can monitor the energy to grid and from grid through the whole day and achieve the export control function with a higher accuracy.

⚠ CAUTION!

- The inverter will shut down and prompt a **Meter Fault** alarm if a meter is not connected to inverter (under G98/1 and G99/1 safety regulation). Under such circumstance, please disable the **Export Control** function in the inverter setting. The **Export Control** is disabled by default, if an error occurs, please check if it is disabled.
- Smart meters must be authorized by our company. Unauthorized meter may be incompatible with the inverter, thereby resulting in inverter damage and working mode malfunction. SolaX will not be responsible for the impact caused by the use of other appliances.
- Please make PE connection for Meter if the meter has ground terminal.

Meter connection procedure

- For meter with CT

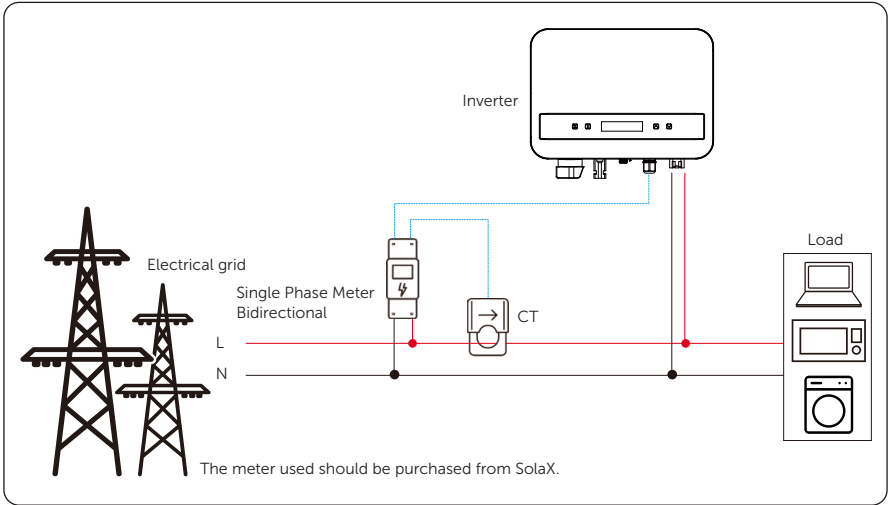

Figure 7-29 Wiring diagram-meter with CT

- For meter without CT

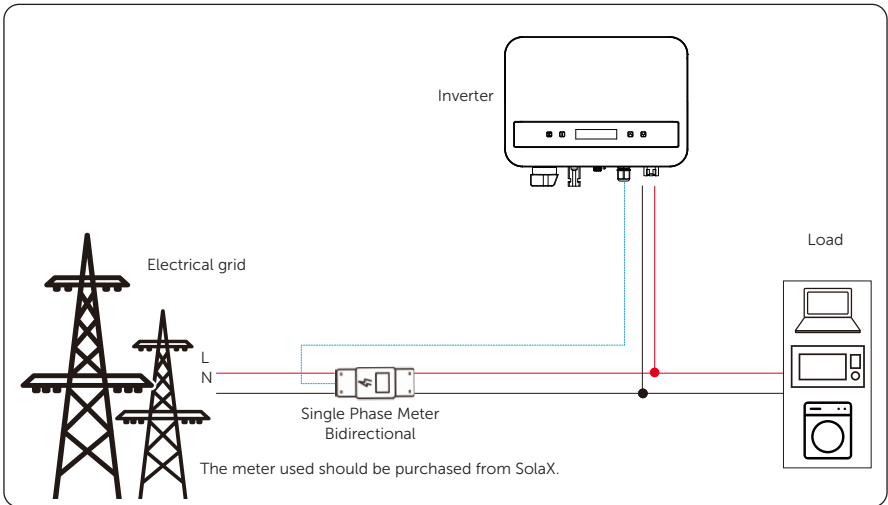

Figure 7-30 Wiring diagram-meter without CT

Table 7-7 PIN definition of meter

PIN	1	2	3	4	5	6	7	8
Definition	X	X	X	485_A	485_B	X	X	X

Please see the *Quick Guide or User Manual of Single Phase Meter* for details.

Wireless meter connection procedure

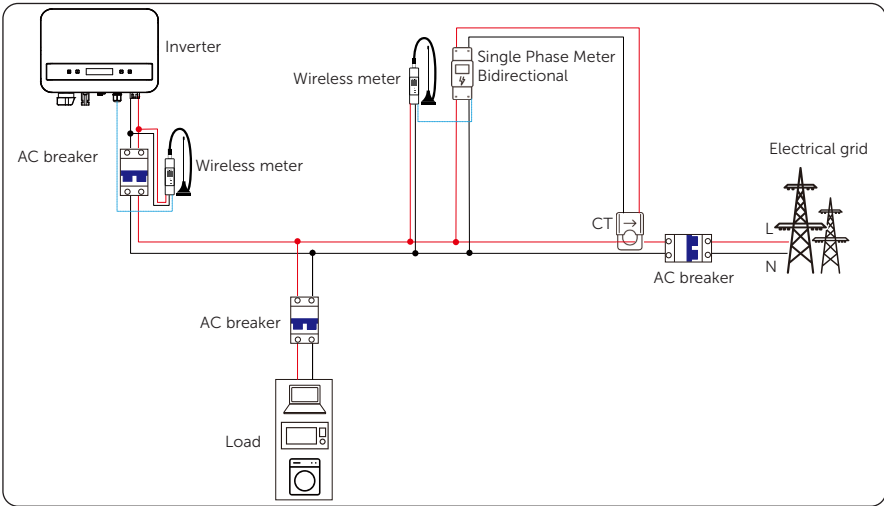

Figure 7-31 Wiring diagram-wireless meter

Table 7-8 PIN definition of meter

PIN	1	2	3	4	5	6	7	8
Definition	X	X	X	485_A	485_B	X	X	X

Please see the *Quick Guide of Wi-BR* for details.

7.5.3 CT Connection

The inverter should work with an electric meter or current transformer (CT for short) to monitor household electricity usage. The electricity meter or CT can transmit the relevant electricity data to the inverter or platform.

CAUTION!

- It is recommended to connect our smart meter or CT to the inverter. If there is no smart meter or CT installed, please disable the **Export Control** function in the inverter setting. Otherwise the inverter will shut down and report a **CT Fault** alert (under G98/1 or G99/1 safety regulations). The **Export Control** is disabled by default, if an error occurs, please check if it is disabled.
- SolaX will not be responsible for the impact caused by the use of other appliances.

NOTICE!

- Do not place the CT on the N wire or ground wire.
- Do not put CT on the N wire and L wire at the same time.
- Do not place the CT on the side where the arrow points to the inverter.
- Do not place the CT on non-insulated wires.
- The cable length between CT and inverter should not exceed 25 meters.
- After CT is connected, prevent the CT clip from falling off.
- It is recommended to wrap the CT clip around in circles with insulating tape.

CT connection diagram

- CT connection diagram

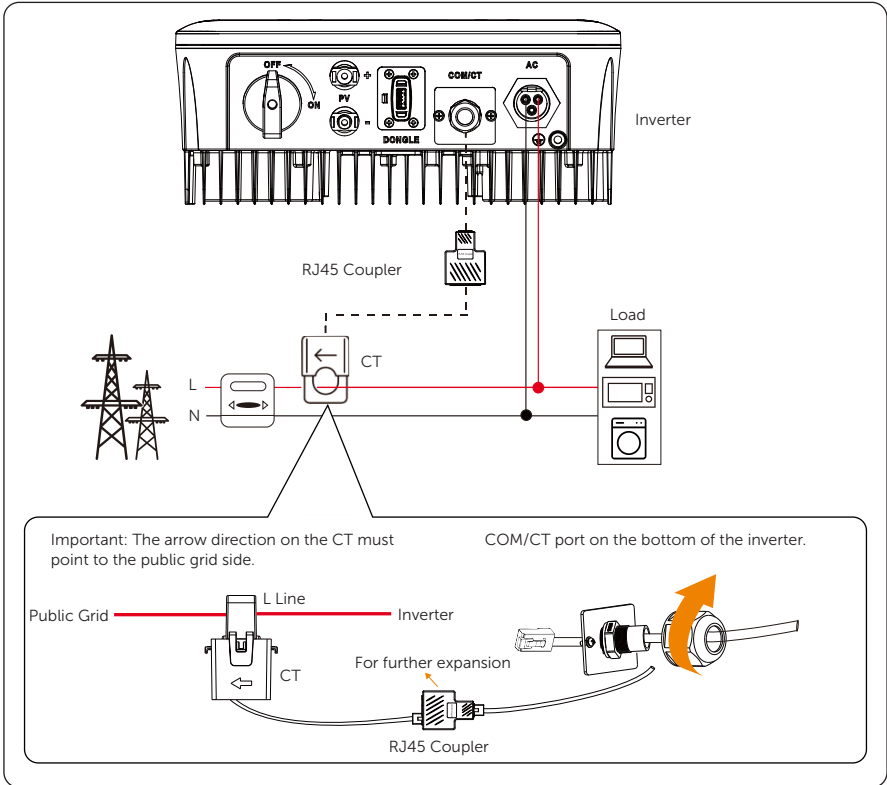

Figure 7-32 CT connection diagram

Table 7-9 PIN definition of CT

PIN	1	2	3	4	5	6	7	8
Definition	CT+	X	X	X	X	X	X	CT-

CT wiring procedure

Step 1: Firstly unscrew the screw from the COM/CT port. (PH1 cross screwdriver. Torque: $1.0 \pm 0.1 \text{ N}\cdot\text{m}$)

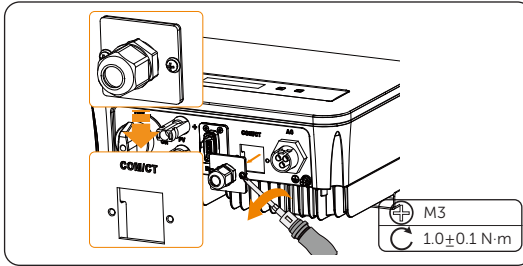

Figure 7-33 Disassemble COM/CT port

Step 2: Prepare a communication cable and strip the insulation from it.

Step 3: Thread the communication cable through the waterproof connector, then insert it into the connector following the PIN definition rule.

Step 4: Insert the RJ45 terminal of CT into the "COM/CT" port on the inverter, and screw down the screw cap tightly.

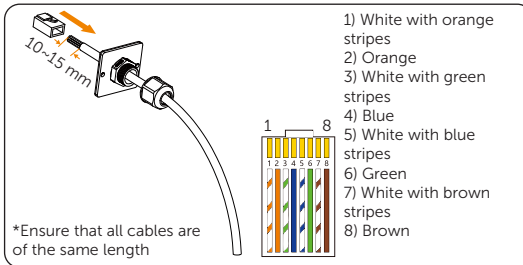

Figure 7-34 Insert the communication cable

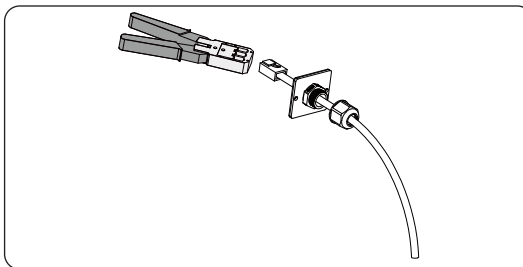

Figure 7-35 Crimp the RJ45 terminal

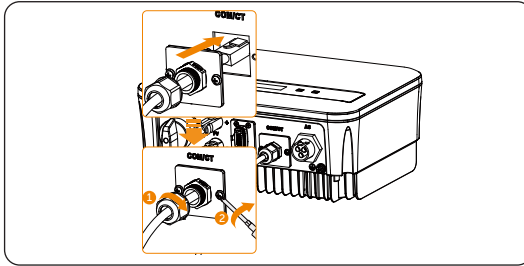

Figure 7-36 Insert the terminal into COM/CT port

- Step 5:** Make sure the current sensor is installed in the right direction: The arrow on the current sensor must point to the public grid.
- Step 6:** Clip the CT clamp on L line from the home main meter box side.
- Step 7:** Use the insulating tape to prevent CT from falling off.

7.5.4 DRM Connection

DRM function (for AS4777) is provided to support several demand response modes by giving control signals as below (For other countries, DRM function is used for remote shut-off). The user should follow the PIN rules below and cooperate with external equipment when using it.

Table 7-10 PIN definition of DRM

PIN	1	2	3	4	5	6	7	8
Definition	X	DRM0	X	X	X	X	+3.3V	X

DRM shares the terminal with RS485/ Meter communications. For the connection steps of the DRM, user can refer to the above RS485 connections.

NOTICE!

- Only DRM0 is available now. DRM0 is for AS4777.2 AU/NZ.

7.6 Dongle Port Connection

The inverter provides a Dongle terminal, which can transmit data of the inverter to the monitoring website via WiFi+LAN dongle (Optional). The WiFi+LAN dongle is equipped with two kinds of communication modes (Wi-Fi mode or LAN mode). Users can choose based on actual needs. (If needed, purchase products from us.)

Monitoring connection diagram

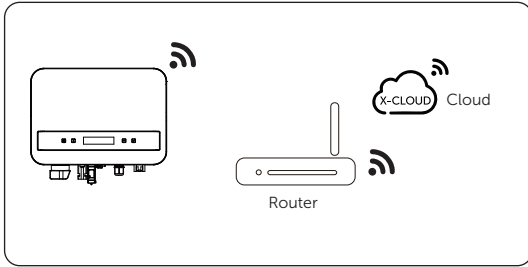

Figure 7-37 Wi-Fi mode connection diagram

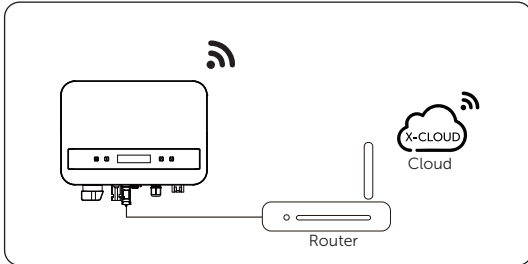

Figure 7-38 LAN mode connection diagram

Monitoring wiring procedure

Wi-Fi mode:

- a. Assemble the dongle.

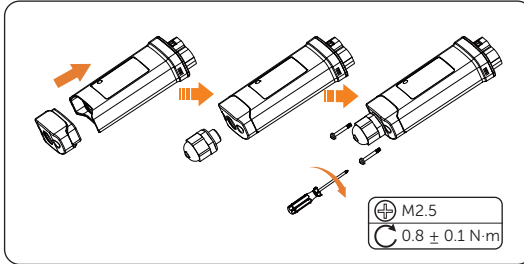

Figure 7-39 Assembling the dongle

- b. Plug the dongle to the inverter.

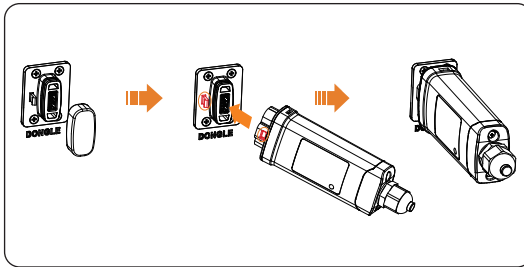

Figure 7-40 Dongle connection procedure

CAUTION!

- The buckles on the inverter and dongle must be on the same side. Otherwise, the dongle may be damaged.

NOTICE!

- The distance between the router and the inverter must be no more than 100 meters. If there are walls in between, the distance must be no more than 20 meters.
- For locations where Wi-Fi signals are weak, install a Wi-Fi signal booster.

NOTICE!

- For details on Wi-Fi configuration, see *Pocket WiFi + LAN Installation Manual*. You can configure Wi-Fi only after the inverter is powered on.

LAN mode:

- a. Disassemble the waterproof connector into components 1, 2, 3 and 4; Component 1 is not used. Keep it in a safe place.

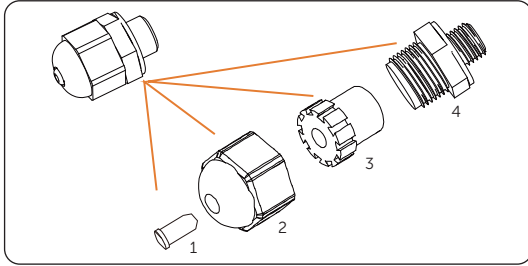

Figure 7-41 Disassembling the waterproof connector

- b. Assemble the dongle.

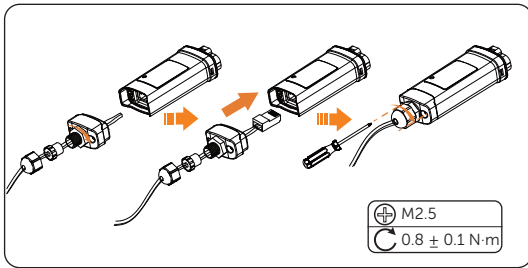

Figure 7-42 Assembling the dongle

- c. Plug the dongle to the inverter.

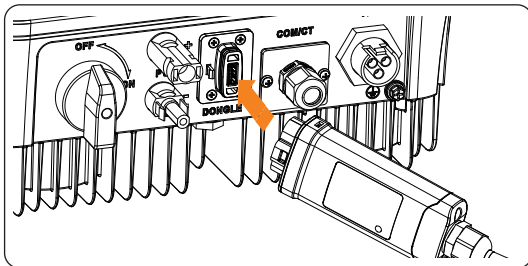

Figure 7-43 Plug in the dongle

8 System Commissioning

8.1 Checking before Power-on

No.	Item	Checking details
1	Installation	The inverter is installed correctly and securely. Other device (if any) is installed correctly and securely.
2	Wiring	All DC, AC cables and communication cables are connected correctly and securely; The meter/CT is connected correctly and securely. The ground cable is connected correctly and securely;
3	Breaker	All the DC breakers and AC breakers are OFF;
4	Connector	The external AC and DC connectors are connected; The connectors on the AC terminal are connected correctly and securely.
5	Unused terminal	Unused terminals and ports are locked by waterproof caps.
6	Screw	All the screws are tightened.

8.2 Powering on the System

Step 1: Turn on the DC switch and switch on the AC breaker. (For the operation of lockable DC switch, please refer to "8.3 Lockable DC switch".)

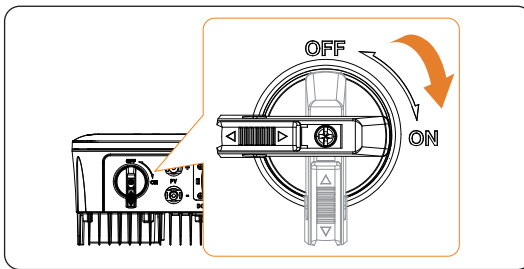

Figure 8-44 Turn on DC switch

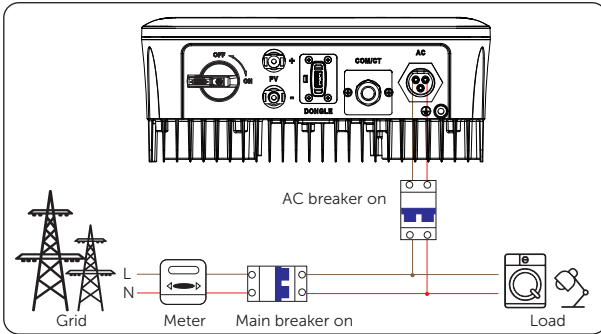

Figure 8-45 Turn on the AC breaker

Step 2: When the photovoltaic panel generates enough power, the inverter will start automatically. The inverter will go Waiting, Checking and Normal status in sequence.

Waiting: The auxiliary power supply of the inverter has been started and the inverter is successfully connected to the mains and waiting for the PV side to meet the working requirement.

Checking: The inverter will automatically detect the DC input. When the photovoltaic panel has enough energy to start the inverter, the inverter will perform self-checks, such as insulation detection, RCD tests.

Normal: The inverter starts to work normally, the operation indicator light is steady in blue. At the same time, the power is fed back to the grid, and the LCD displays the output power.

WARNING!

- Power to the unit must be turned on only after installation work has been completed.
- All electrical connections must be carried out by qualified personnel in accordance with legislation in force in the country concerned.

NOTICE!

- Please set the inverter according to local requirements.

8.3 Lockable DC switch

This series of inverters are provided with two kinds of DC switches: unlockable DC switch (standard; without lock) and lockable DC switch (optional; with lock).

Lockable DC switch is divided into two types, please use it according to the accessory in the packing list and the corresponding instructions as follows.

For lockable DC switch (mode 1):

The lockable DC switch includes 3 states: ON, OFF, and OFF+Lock. The DC switch is in the OFF state by default.

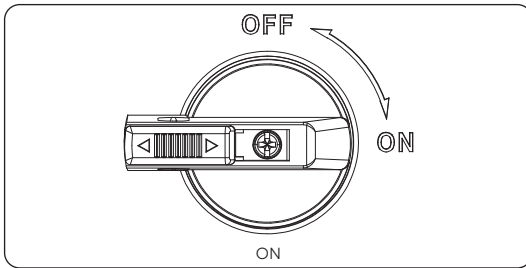

Figure 8-46 ON state

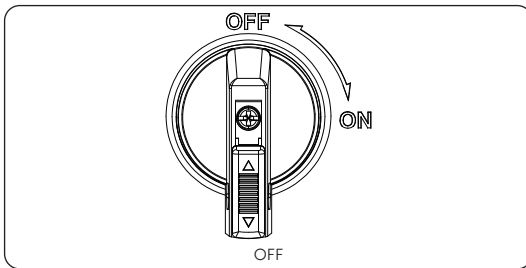

Figure 8-47 OFF state

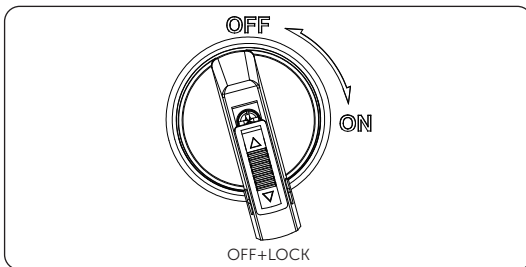

Figure 8-48 OFF+LOCK state

- To turn on the DC switch
 - a. Turn on the DC switch from OFF state to ON state.

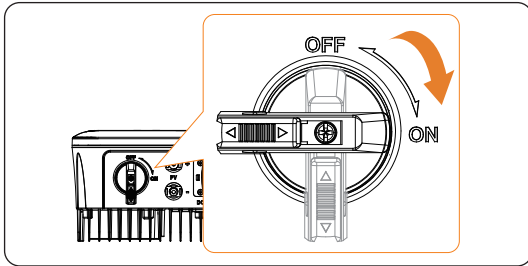

Figure 8-49 Turn on DC switch

- To turn off the DC switch
 - a. Rotate the DC switch from ON state to OFF state.

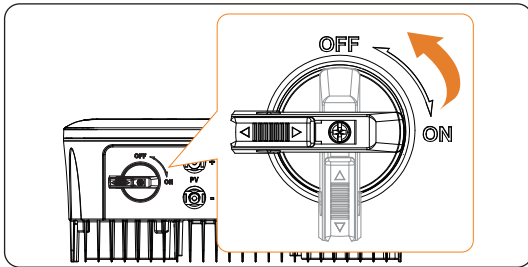

Figure 8-50 Turn off DC switch

- To lock the DC switch
 - a. Rotate the lock to the left side;
 - b. Push the lock upward (as shown in the diagram below).
 - c. Secure the DC switch with a lock (Please prepare a lock in advance).

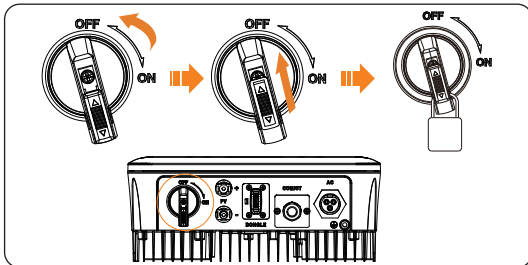

Figure 8-51 Lock DC switch

- To unlock the DC switch
 - a. Remove the lock.
 - b. Push the lock down (as shown in the diagram below);
 - c. Wait for it to return to OFF state.

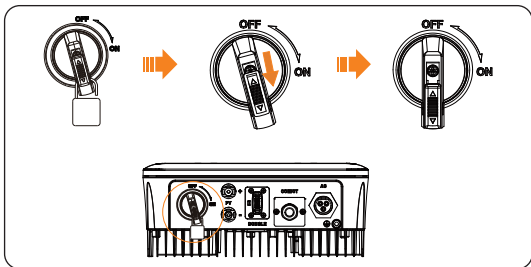

Figure 8-52 Unlock DC switch

For lockable DC switch (mode 2):

The lockable DC switch includes 3 states: ON, OFF, and OFF+Lock. The DC switch is in the OFF state by default.

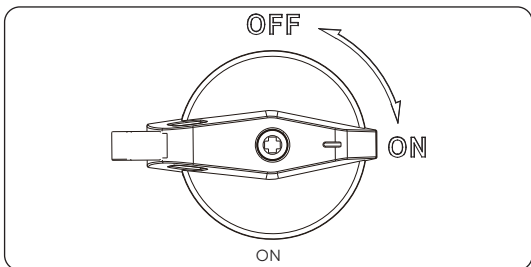

Figure 8-53 ON state

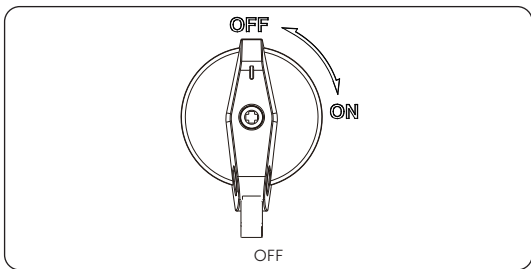

Table 8-11 OFF state

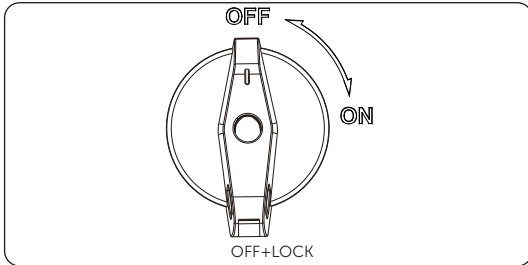

Figure 8-54 OFF+LOCK

- To turn on the DC switch
- a. Turn on the DC switch from OFF state to ON state.

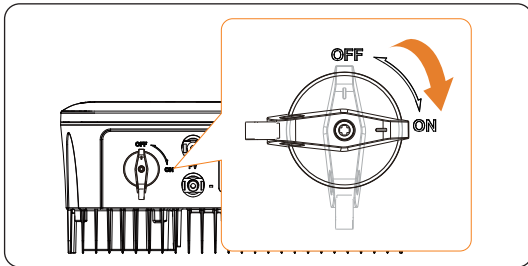

Figure 8-55 Turn on DC switch

- To turn off the DC switch
- a. Rotate the DC switch from ON state to OFF state.

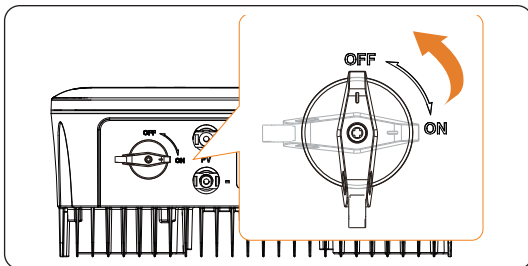

Figure 8-56 Turn off DC switch

- To lock the DC switch
- a. Make sure the DC switch is OFF state, push in the buckle as shown below, and then secure it with a lock (Please prepare a lock in advance.)

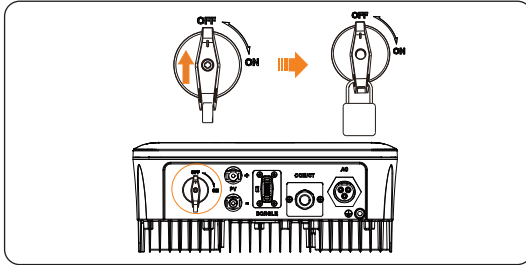

Figure 8-57 Lock DC switch

- To unlock the DC switch
- a. Remove the lock and wait for it to return to OFF state.

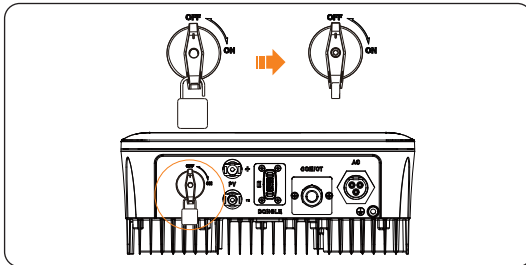

Figure 8-58 Unlock DC switch

8.4 Checking after Power-on

Step 3: Check the status of LED indication and LCD screen, the LED indication should be blue and the LCD screen should display the main interface. If the LED indication is not blue, please check the following conditions:

- » All the connections are correct.
- » All the external disconnect switches are closed.
- » The DC switch of the inverter is in the "ON" position.

8.5 Isolation Fault Alarm

The isolation fault alarm installed into the inverter, is the standard configuration, as required by AS 4777_2020 and New Zealand, it will give a visual alarm once the isolation impedance of the PV arrays is less than 20 K Ω .

The error indicator light will be in red and the control panel will display isofault.

8.6 Country/Grid Settings

For compliance with AS/NZS 4777.2:2020, please select from Australia Region A/B/C. Please contact your local grid operator for which Region to select.

- Please select Australia Region A, B, C for power quality response modes and grid protection settings during commissioning.

- You can adjust setpoints for power quality response modes and grid protection settings if required.

8.7 Commissioning

You can adjust setpoints for power quality response modes and grid protection settings if required.

After commissioning, you can view the following settings through the LCD of the inverter after commissioning: Region settings (and setpoints) for grid protection settings Region settings (and setpoints) for power quality response modes.

NOTICE!

- Once settings are selected at commissioning they are locked to view only.

NOTICE!

- Password should not be readily available – if you need that, you can find the password that either in a separate maintenance/service manual or available from manufacturer/importer upon request.

9 Operation on LCD

9.1 Introduction of Control Panel

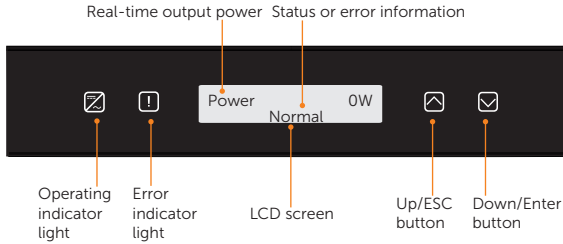

Figure 9-1 Control panel

- In a normal state, the **Power, Pgrid, Today, and Total** information will be displayed. You can press the keys to switch information.
- In an error state, the fault message and error code will be displayed, please refer to "11.2 Troubleshooting" for corresponding solutions.

Table 9-1 Definition of indicators







LED indicator	Status	Definition
 Operating		Light on The inverter is in a normal state.
		Blinking The inverter is in a waiting or checking state.
 Error		Light on The inverter is in a fault state.

Table 9-2 Definition of keys

Key	Definition
 UP/ESC key	Short press to move cursor up or increase value. Long press to return from the current interface function.
 DOWN/Enter key	Short press to move cursor down or decrease value. Long press to confirm and change parameters.

9.2 Introduction of Main Interface

The main interface is the default interface, the inverter will automatically jump to this interface when the system starts up successfully or is not operated for a period of time.



The first line shows the following information:

Power means the timely output power;

Pgrid means the power export to or import from the grid (Positive value means the energy feeds into the grid, negative value means the energy used from the grid);

Today means the energy generated within the day;

Total means the energy generated until now. The second line shows the running status of the inverter.

Normal means the inverter is in normal status.

When the inverter is in fault status, the error code and information will be displayed.

9.3 Introduction of Menu Interface

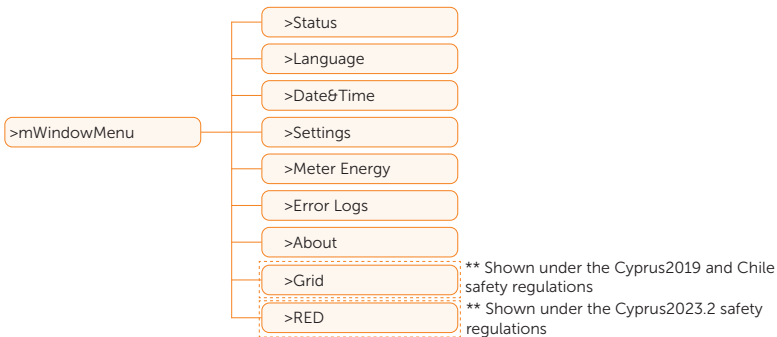

When the inverter shows the default interface, long press **Enter** key to enter the menu interface. There are eight submenus in the menu that can be selected for relevant operations.



Status: Display the real-time value of the inverter, including **Grid** and **Solar**.

Language: Set the language displayed on the inverter.

Date&Time: Set the date and time.

Settings: Set the parameters of the inverter.

Meter Energy: Display the import and export energy information of the inverter.

Error Logs: Display the error logs of the inverter.

About: Display the information about the inverter.

Grid: Display the grid protection parameters. Only Shown under the Cyprus2019 and Chile safety regulations.

RED: Display the grid service and PF(P) parameters. Only shown under the Cyprus2023.2 safety regulations.

9.3.1 Status

Status display the real-time value of the inverter, including **Grid** and **Solar**.

Short press Up and Down to select and long press Down to confirm the selection, long press Up to return to Menu.

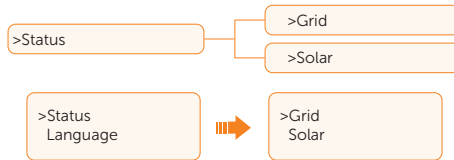

Grid

This status shows the current condition of the AC output port of the inverter, such as voltage, current, output power and grid power. This status includes 5 parameters: **U**, **I**, **F**, **Pout**, **Pgrid**.

- » **U:** The voltage of the AC output of the inverter.
- » **I:** The current of the AC output of the inverter.
- » **F:** The frequency of the AC output of the inverter.
- » **Pout:** A parameter that measures the output power of the inverter.
- » **Pgrid:** A parameter that measures power export to or import from the grid. Positive value means the power feeds into the grid, negative value means the power used from the grid.

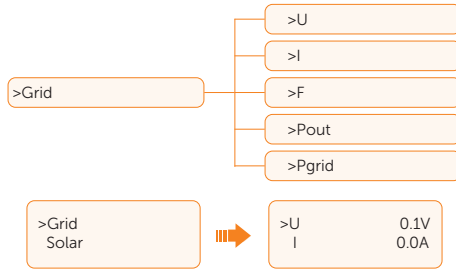

Solar

This parameter shows the real time PV condition of the system, such as input voltage, current and power of each PV input. This status includes 3 parameters: **U1, I1, P1**.

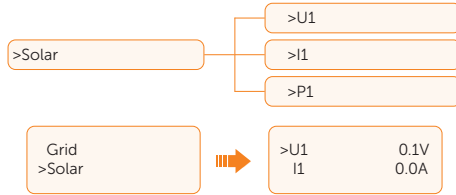

9.3.2 Language

Users can select a language from **English, German, Polish, French, Portuguese, Chinese, Spanish, Italian, Dutch** and **Czech** by this function.

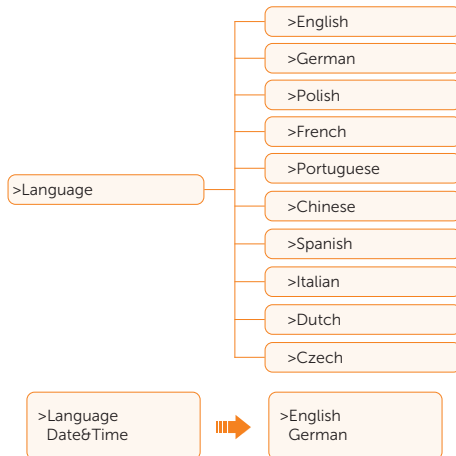

9.3.3 Date&Time

You can set the current date and time of the installation site. The display format is "2024-01-01 00:00", in which the first four numbers represent the year (e.g. 2000~2099); the fifth and sixth numbers represent the month (e.g. 01~12); the seventh and the eighth numbers represent the date (e.g. 01~31). The remaining numbers represent the time.

Increase or decrease the word by pressing Up or Down button. Long press Down to confirm and alternate to next parameter. After all the numbers are confirmed. Long press Down to enter the date and time.



9.3.4 Setting

This function is used for setting the inverter.



Password

The default password is **2014** for the installer, which only allows the installer to review and modify necessary settings complying to the local rules and regulations. If further advanced setting is required, please contact the distributor or us for assistance.

Press up or down button to increase or decrease the number. Long press Down to confirm and short press to alternate to the next number. After inputting the password, you can view the submenus of the setting parameters.



NOTICE!

- All the adjustable parameters including safety code, grid parameter, export control, etc. can be modified under the permissions of installer password. Unauthorized use of the installer password by unauthorized persons can lead to incorrect parameters being inputted, resulting in power generation loss or violation of local regulation.
- Replace the password with a new secure password for the consideration of account security.

9.3.5 Meter Energy

The user can check the import and export energy by this function. There are two parameters: **Total Import**, **Total Export**. Only when a meter or CT is installed in the system can the inverter accumulate the energy takes from or feeds into the grid. If there is no meter or CT in the system, the value will be 0. Press Up and Down to browse the values.

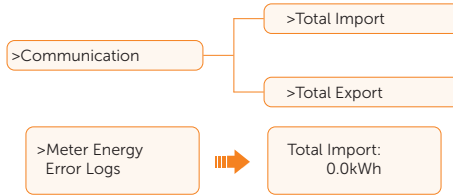

9.3.6 Error Logs

The Error log contains error information happened. It can record six items at most. Press Up and Down button to review parameter. Long press Up to return to the main interface.



9.3.7 About

This interface shows information of the inverter, including **Product SN**, **Register SN**, **Master**, **Manager** and **Internal Code**.

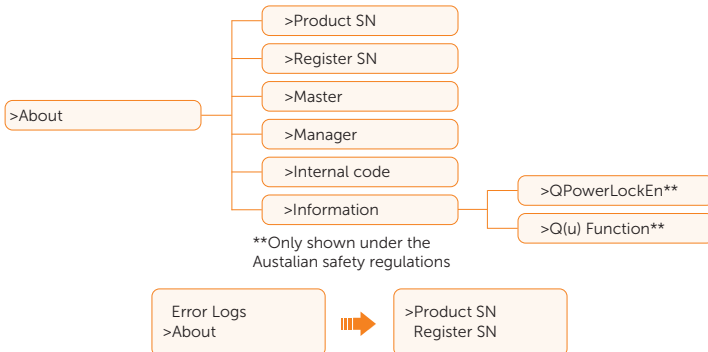

Table 9-3 Items under **About**

Information	Comment
QPowerLockEn	Enable
	Disable
	Pu_GridV1
	Pu_GridV2
	Pu_GridV3
	Pu_GridV4
	Pu_PowerRatio1
	Pu_PowerRatio2
	Pu_PowerRatio3
	Pu_PowerRatio4
	Pu_3Tau
Q(u) Function	QPowerLockEn
	QuLockIn
	Qu_GridV1
	Qu_GridV2
	Qu_GridV3
	Qu_GridV4
	QuRatio1
	QuRatio2
	QuRatio3
	QuRatio4

9.3.8 Grid

This function is only shown under the Cyprus2019 and Chile safety regulations to display grid service parameters.



9.3.9 RED

This function is only shown under the Cyprus2023.2 safety regulations to display grid service parameters.



9.4 Detailed Operation of Settings

Safety

The user can set the safety standard here according to different countries and grid tied standards. There are several standards for choice (May change without notice). In addition, the user has a **UserDefined** option which allows the user to customize relevant parameters within a wider range.



NOTICE!

- The grid standard needs to be set as different regions according to local requirements. If there is any doubt, please consult our service technicians for details.
- The inverter cannot be connected to the grid before the safety code is correctly set. If there is any doubt about your safety code where the inverter installed, please consult your dealer or SolaX service for details.
- The setup will vary from different safety codes.

System will take effect according to the corresponding safety regulations.

Table 9-4 Region settings

Region	Australia A	Australia B	Australia C	New Zealand	
Standard Code Name	AS4777_2020_A	AS4777_2020_B	AS4777_2020_C	New Zealand	Setting Range
OV-G-V	265 V	265 V	265 V	265 V	230-300 V
OV-GV1-T	1.5 s	1.5 s	1.5 s	1.5 s	
OV-G-V2	275 V	275 V	275 V	275 V	230-300 V
OV-GV2-T	0.1 s	0.1 s	0.1 s	0.1 s	
UN-G-V1	180 V	180 V	180 V	180 V	40-230 V
UNGV1-T	10 s	10 s	10 s	10 s	

Region	Australia A	Australia B	Australia C	New Zealand	
Standard Code Name	AS4777_2020_A	AS4777_2020_B	AS4777_2020_C	New Zealand	Setting Range
UN-G-V2	70 V	70 V	70 V	70 V	40-230 V
UNGV2-T	1.5 s	1.5 s	1.5 s	1.5 s	
OV-G-F1	52 Hz	52 Hz	55 Hz	55 Hz	50-55 Hz
OVGf1-T	0.1 s	0.1 s	0.1 s	0.1 s	
OV-G-F2	52 Hz	52 Hz	55 Hz	55 Hz	50-55 Hz
OVGf2-T	0.1 s	0.1 s	0.1 s	0.1 s	
UN-G-F1	47 Hz	47 Hz	45 Hz	45 Hz	40-50 Hz
Region	Australia A	Australia B	Australia C	New Zealand	
Standard Code Name	AS4777_2020_A	AS4777_2020_B	AS4777_2020_C	New Zealand	Setting Range
UNGF1-T	1.5 s	1.5 s	5 s	1.5 s	
UN-G-F2	47 Hz	47 Hz	45 Hz	45 Hz	45-50 Hz
UNGF2-T	1.5 s	1.5 s	5 s	1.5 s	
Startup-T	60 s	60 s	60 s	60 s	15-1000 s
Restore-T	60 s	60 s	60 s	60 s	15-600 s
Recover-VH	253 V	253 V	253 V	253 V	
Recover-VL	205 V	205 V	205 V	198 V	
Recover-FH	50.15 Hz	50.15 Hz	50.15 Hz	50.15 Hz	
Recover-FL	47.5 Hz	47.5 Hz	47.5 Hz	47.5 Hz	
Start-VH	253 V	253 V	253 V	253 V	
Start-VL	205 V	205 V	205 V	198 V	
Start-FH	50.15 Hz	50.15 Hz	50.15 Hz	50.15 Hz	
Start-FL	47.5 Hz	47.5 Hz	47.5 Hz	47.5 Hz	

Export Control

With this function the inverter can control the power exported to the grid. Whether having this function is based on user's wishes.

Choose **Disable** means the function will be shut off.

The user value set by installer must be within the range of 0 kW to 60 kW. Press Up and Down button to select and long press Down to confirm.

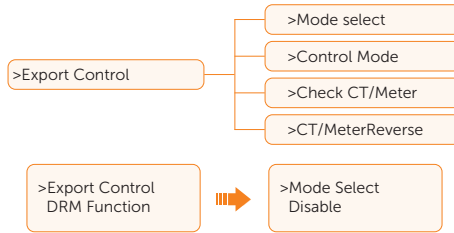

DRM Function

Installer can choose **Enable** to control the inverter's power off through the external communication



Grid Services

Usually end user do not need to set the grid parameters. All default value have been set before leaving factory according to safety rules.

If reset is needed, any changes should be made according to the requirements of local grid.

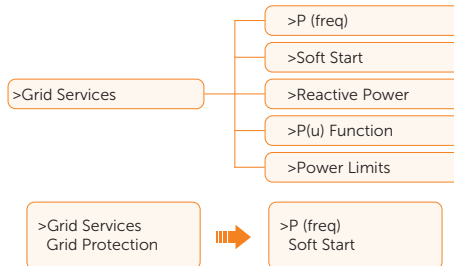

- **P (freq):** If reset is needed, any changes should be made according to the requirements of local grid.

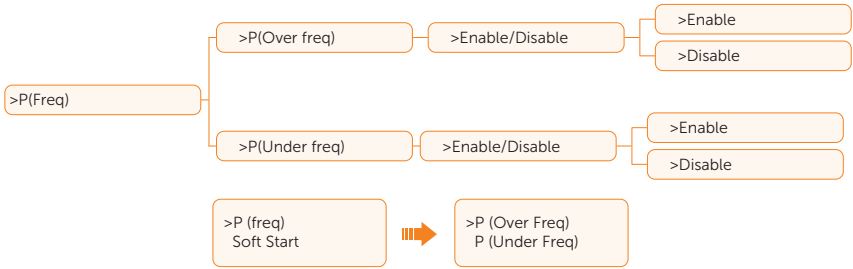

- **Soft Start:** If reset is needed, any changes should be made according to the requirements of local grid.

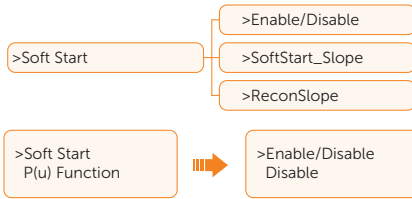

- **P(u) Function:** This function is used to set the active power curve of the voltage.

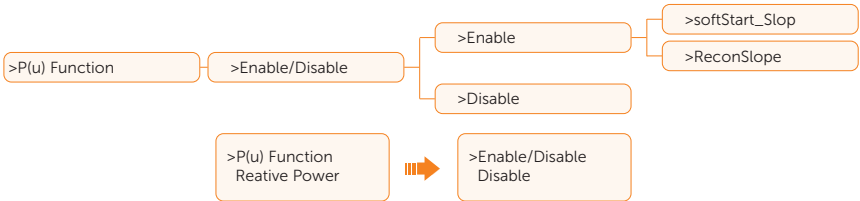

Table 9-5 Items under **P(u) Function**

Item	Sub-item
P(u) Function	Enable
	Disable
	PuGridV1
	PuGridV2
	PuGridV3
	PuGridV4
	Pu_Ratio1
	Pu_Ratio2
	Pu_Ratio3
	Pu_Ratio4
	Pu_3Tau

» For AS/NZS 4777.2, the curve required for the volt-watt mode can be referred to the curve below.

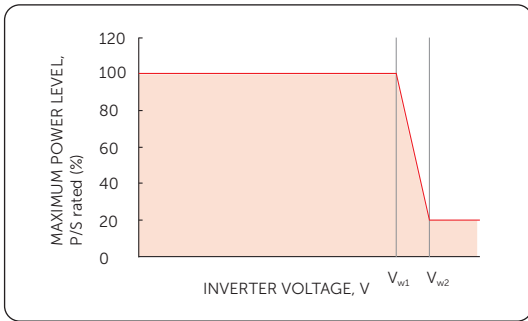

Figure 9-2 Curve for P(u)

- **Reactive Power:** If reset is needed, any changes should be made according to the requirements of local grid.

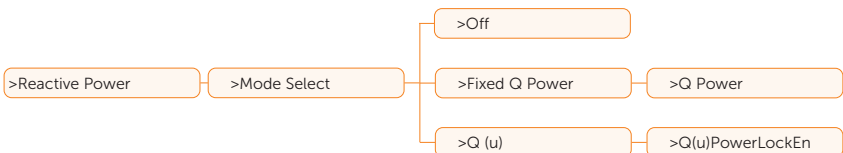



Table 9-6 Items under **Reactive Power**

Mode Select	Comment
Off	-
Over-Excited	PF Value
Under-Excited	PF Value
PF(P)	PowerFactor 1
	PowerFactor 2
	PowerFactor 3
	PowerFactor 4
	PowerRatio 1
	PowerRatio 2
	PowerRatio 3
	PowerRatio 4
	EntryVolt
	ExitVolt
	PF(p)_3Tau

Operation on LCD

Mode Select	Comment
Q(u)	Q(u) PowerLockEn
	CurVeSetting (Only shown under EN50549_1 safety regulation)
	Q(u)Lockin
	Q(u) LockOut
	Q(u)GridV1
	Q(u)GridV2
	Q(u)GridV3
	Q(u)GridV4
	QuQ1
	QuQ2
	QuQ3
	QuQ4
	Qu_3Tau
	mincosf
	mincosfEn (Only shown under EN50549_1 safety regulation)
Fixed Q Power	Q Power
	FIX_Q 3Tau (Only shown under EN50549_1 safety regulation)
	QPowerLockEn (Only shown under EN50549_1 safety regulation)
	CurVeSetting (Only shown under EN50549_1 safety regulation)
	Qratio1 (Only shown under EN50549_1 safety regulation)
	Qratio2 (Only shown under EN50549_1 safety regulation)
	Qratio3 (Only shown under EN50549_1 safety regulation)
	Qratio4 (Only shown under EN50549_1 safety regulation)
	PowerRatio1 (Only shown under EN50549_1 safety regulation)
	PowerRatio2 (Only shown under EN50549_1 safety regulation)
PowerRatio3 (Only shown under EN50549_1 safety regulation)	
PowerRatio4 (Only shown under EN50549_1 safety regulation)	
Q(p) (Only shown under EN50549_1 safety regulation)	

Mode Select	Comment
Q(p) (Only shown under EN50549_1 safety regulation)	EntryVolt (Only shown under EN50549_1 safety regulation)
	ExitVolt (Only shown under EN50549_1 safety regulation)
	Qp_3Tau (Only shown under EN50549_1 safety regulation)

- Reactive power control, reactive power standard curve $\cos \varphi = f(P)$
 - For VDE ARN 4105, the curve $\cos \varphi = f(P)$ should refer to curve A. The set default value is shown in curve A.

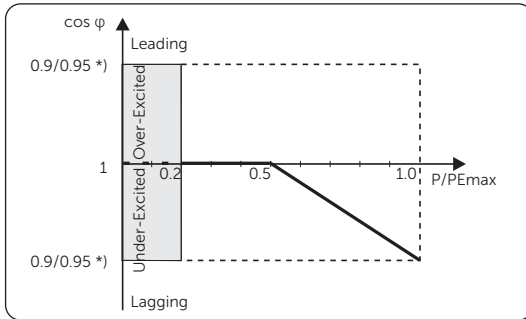

Figure 9-3 Curve A

(*) If the P_{max} of the inverter ≤ 4.6 kW, the Power Factor is 0.95 at 1.0 power;
 if the P_{max} of the inverter > 4.6 kW, the Power Factor is 0.90 at 1.0 power.

- Reactive power control, reactive power standard curve $Q = f(V)$

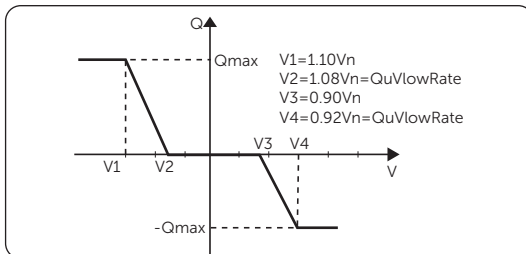

Figure 9-4 Curve $Q = f(V)$

- » For AS/NZS 4777.2, the curve required for the volt-var control mode can be referred to the curve below.

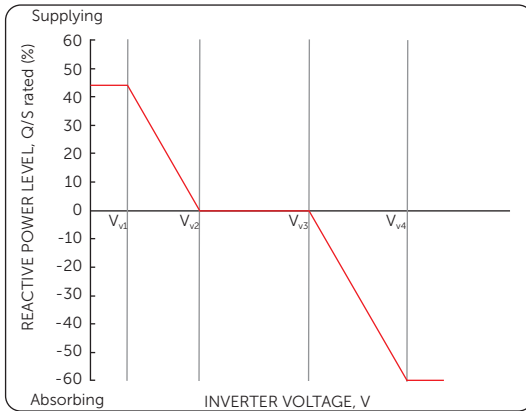

Figure 9-5 Curve for Q(u)

- » For VDE 4105, curve $\cos \varphi = f(P)$ should refer to curve A. The default setting values are as shown in the curve below.

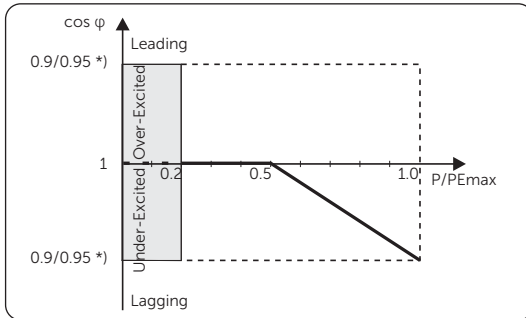

Figure 9-6 Curve A

- » For TOR, curve $\cos \varphi = f(P)$ should refer to curve B. default values of setting are as shown in the curve below.

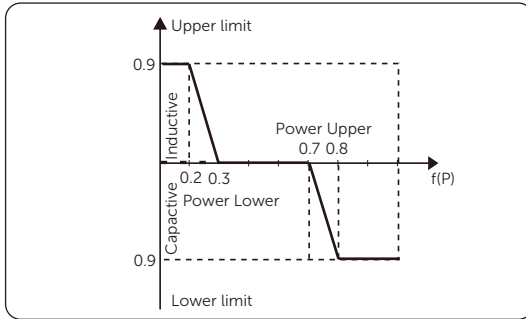

Figure 9-7 Curve B

NOTICE!

- The terms shown in the interface depend on the local safety regulations.
- **PowerLimits:** User can set the power limit here, the setting value is between 0.00 and 1.10.



NOTICE!

- The setting value for X1-MINI-0.6K/0.8K/3.3K-G4 ranges from 0.00 to 1.00.
- If local safety regulations provide otherwise, please follow the local safety regulations.

Grid Protection

Usually end user do not need to set **Grid Protection**. All default values have been set before leaving factory according to safety rules.

If reset is needed, any changes should be made according to the requirements of local grid.

Table 9-7 Items under **Grid Protection**

Parameter	Description
O/V Stage1	Slow overvoltage point
U/V Stage1	Slow undervoltage point
O/V Stage2	Rapid overvoltage point

Operation on LCD

Parameter	Description
U/V Stage2	Rapid undervoltage point
O/V Stage3	Stage-3 rapid overvoltage point
U/V Stage3	Stage-3 rapid undervoltage point
O/V 10min En	10 min average overvoltage enabled
O/V 10min Set	10 min average overvoltage setting value
O/F Stage1	Slow overfrequency point
U/F Stage1	Slow underfrequency point
O/F Stage2	Rapid overfrequency point
U/F Stage2	Rapid underfrequency point
FreqROCOF	Rate of frequency change
H/LVRT Function	High/low voltage ride enabled
Frt_EnterVoltUp	Entry value of high voltage ride through
Frt_EnterVoltDn	Entry value of low voltage ride through
VacOVP1stTime	Stage-1 overvoltage protection time
VacOVP2ndTime	Stage-2 overvoltage protection time
VacOVP3rdTime	Stage-3 overvoltage protection time
VacUVP1stTime	Stage-1 undervoltage protection time
VacUVP2ndTime	Stage-2 undervoltage protection time
VacUVP3rdTime	Stage-3 undervoltage protection time
FacOFP1stTime	Stage-1 overfrequency protection time
FacOFP2ndTime	Stage-2 overfrequency protection time
FacUFP1stTime	Stage-1 underfrequency protection time
FacUFP2ndTime	Stage-2 underfrequency protection time
Connection	Parameter setting once inverter is powered on
ReConnectTime	Reconnection parameter setting after an error is triggered
VAC10MAvgT	10 min overvoltage detecting time
LVRT_O_Current	Low voltage ride through current enable

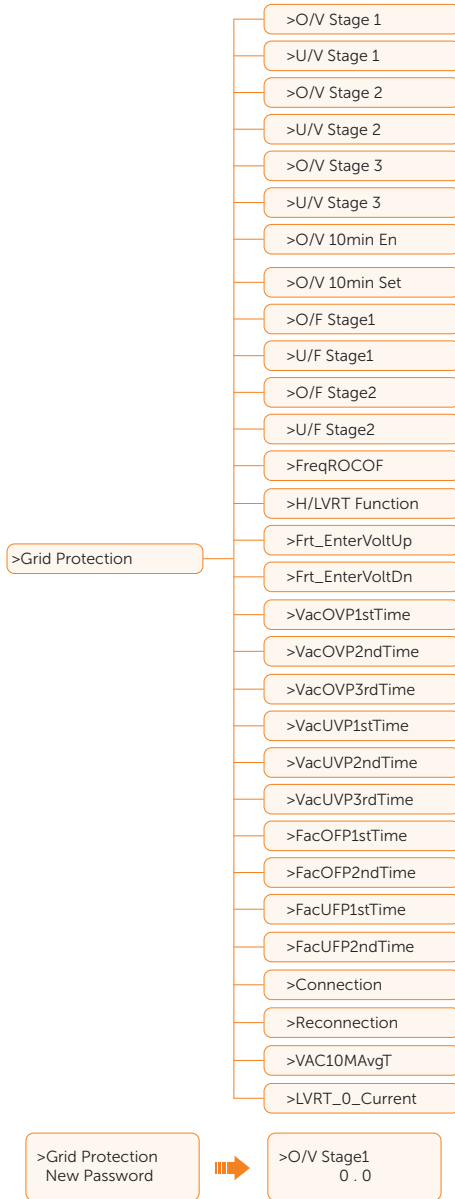

New Password

The user can set the new password here. We need to increase or decrease the number by pressing Up or Down button. Long press Down to confirm and alternate to next number. After the number is confirmed, long press Down to reset the password.



Communication

By this function, users can set RS485 communication, and shut down and power on of the slave inverter.

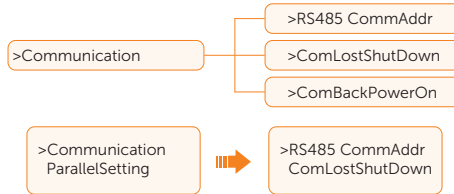

- **RS485 CommAddr**

If **Enable** is selected, the inverter will communicate with the computer, through which the operating status of the inverter can be monitored. When multiple inverters are monitored by one computer, RS485 communication addresses of different inverters need to be set. RS485 function will only be effective when the address is identical. The default address is **1**.



- **ComLostShutDown**

If **Enable** is selected, when the communication between the master inverter and slave inverters are loss for a certain period, the slave inverter will proactively stop generate power and stay in the waiting status.

This function is exclusive for parallel connection of inverters with DataHub or ModBus.



- **ComBackPowerOn**

When this function is turned on, when the communication between the master inverter and slave inverters is recovered, the slave inverters will be powered on.

This function is exclusive for parallel connection of inverters with DataHub or ModBus.



ParallelSetting

When the user wants to use the parallel system with Modbus Function, enable this function and complete the settings, please refer to the instructions in section "[14.5 Application of Parallel Connection](#)". If not needed, disable this function.



GMPPT

There are 4 modes for selection: **Off**, **LowFreqScan**, **MidFreqScan**, **HighFreqScan**. It shows the frequency of PV panel scan.

If **LowFreqScan** is selected, the inverter will scan the PV panel by low frequency.

Time for LowFreqScan: 4h; for MidFreqScan: 3h; for HighFreqScan: 1h.



Reset Energy

The user can clear the power energy of CT and meter by this function (if the user uses meters).



Reset Meter

The user can clear the **Meter** and **CT** energy by this function. Press Up or Down button to select and long press Down to confirm. (The user can select Yes to reset meter if the user uses meters)



Reset Errorlog

The user can clear the errorlogs by this function. Press Up or Down button to select and long press Down to confirm. (The user can select Yes to reset meter if the user uses meters)



Reset WiFi

The user can restart the WiFi by this function.



Machine Type

The user can check the **Machine Type** by this function.



EVChargerEnable

The user can turn on EVCharger function by select **Enable**.



Adaptor Box G2

The user can connect the adaptor box by this function.



Earth Detect

The user can enable or disable the **Earth Detect** by this function.



Dry Contact

The user can use the **Dry Contact** to connect heat pump by this function (require SG Ready).



There are three functions(**Disable/Manual/Smart Save**) which can be selected for Load Management. **Disable** means the heat pump is off. When **Manual** is selected the user can control the external relay to remain close or open manually. **Smart Save** mode can set the values of the heat pump's on/off time and conditions, operating modes.

If the user uses the inverter dry contacts to control heat pump through Adapter box, please refer to the *Adapter Box Quick Installation Guide* to set the parameters here.



• **Mode Select**

For **Mode Select**, refer to the description of the "14.1 Application of Generator", "14.3 Application of Adapter Box G2", and "14.2 Application of Adapter Box" for the specific settings.

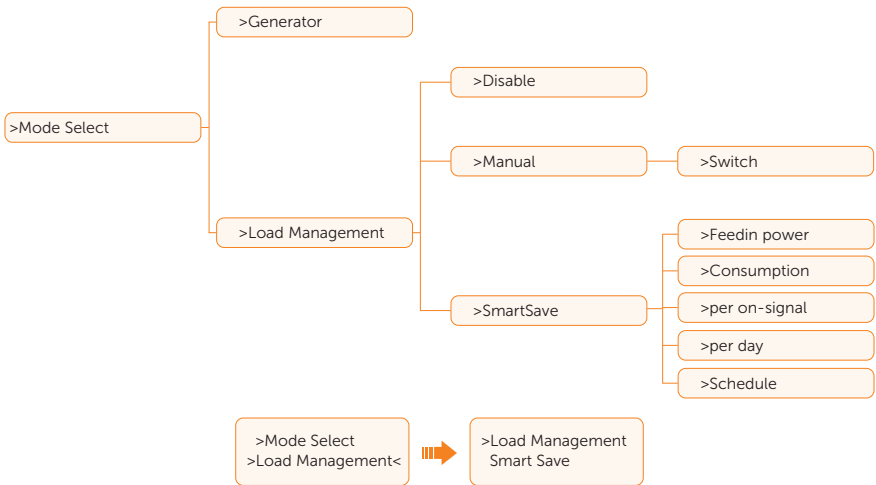

Shutdown Mode

By this function, users can realize remote shutdown function. Select **NO**, the inverter will shut down after short-circuiting; Select **NC**, the inverter will be powered on after short-circuiting.

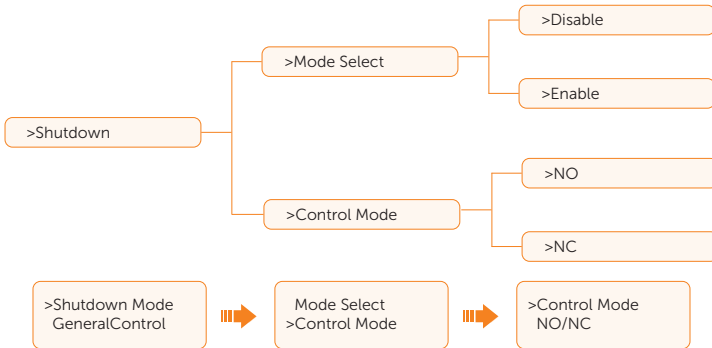

GeneralControl

Under the Australia safety regulations, general control will show as meter control.

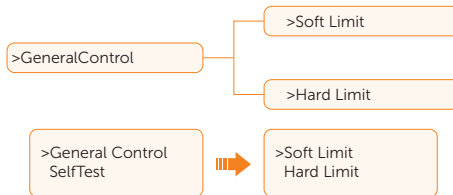

- **Soft Limit**

Soft Limit is only shown under the Australian safety regulation when meter is turned on. If **Soft Limit** is enabled and **Hard Limit** is disabled, export power could be controlled by **Soft Limit**, and the power limits range from 0~4990 W.

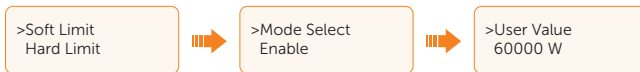

- **Hard Limit**

If **Hard Limit** and **Soft Limit** are enabled at the same time, export power could only be controlled by **Hard Limit**, and the power limits range from 0~4990 W.

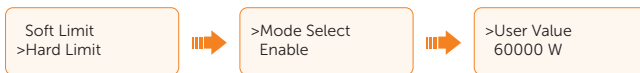

SelfTest

The user can test the safety regulations using this function. This parameter is only shown under the Italian safety regulation (only applied to CEI0_21).

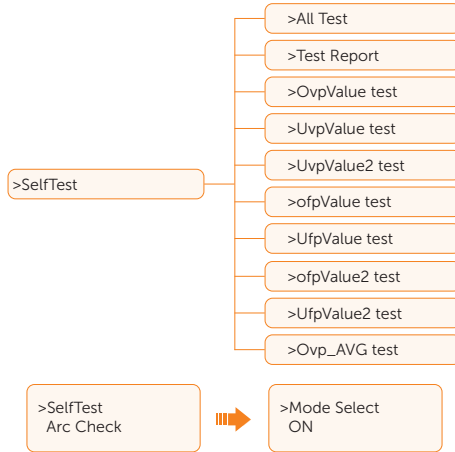

Arc Check

This function is only available for ARC version under the Australian and Italian safety regulations. Users can set the ARC by this function. The inverter has arc detection function, which detects the arcing of the DC side and cuts the circuit in time to protect the user and the electrical system. The arc module of the series inverter meets the requirements of IEC 63027.

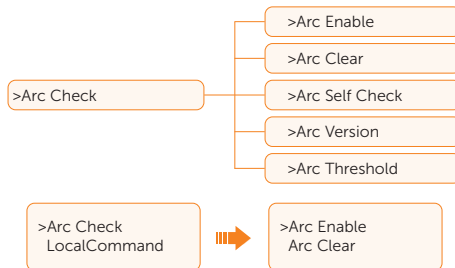

- **Arc Enable**

If **Arc Enable** is selected, the Arc function is enabled. Select Enable in Arc Enable, the inverter will report Arc Fault when faults are detected. When it is disabled, there won't be any reports even when faults occurred.



- **Arc Clear**

If **Arc Clear** is selected, the system will clear all **Arc Fault** (refer to IE:00060 ARC Fault of "11.2 Troubleshooting"). The system will clear fault automatically for 5 times at most. If more than five faults are reported, you need to manually clear the fault. For manual clear, select **YES** in **Arc Clear**, the inverter will clear the arc fault immediately and restart the system.



- **Arc Self Check**

If **Arc Self Check** is selected, the system will self check the arc, and when an error is detected, **ARC Self Test Fault** will be reported (refer to IE:00061 ARC Self Test Fault of "11.2 Troubleshooting"). The function will turn to **Disable** after the checking process is completed.



NOTICE!

- **Arc Self Check** should be done when the inverter is in normal state and the current is greater than 1.5 A. If an **Arc Fault** is reported and displayed on the inverter if turned back the main interface, the arc detection function is working normally.

- **Arc Version**

Arc Version displays the version of arc module.



- **Arc Threshold**

Arc Threshold means the arc sensitivity, ranging from 0-4 W. 0 represents the highest sensitivity, while 4 represents the lowest sensitivity. Arc Threshold can only be set by manufacturers.



LocalCommand

The user can select broadband and narrow band according to local command using this function.



10 Operation on SolaX App and Web

10.1 Introduction of SolaXCloud

SolaxCloud is an intelligent management platform for home energy, which integrates energy efficiency monitoring, device management, data security communication and other integrated capabilities. While managing your home energy device, it helps you optimize the efficiency of electricity consumption and improve the revenue of power generation.

10.2 Operation Guide on SolaXCloud App

10.2.1 Downloading and installing App

Method 1: Select and scan the QR code below to download the app.



Figure 10-1 QR code

NOTICE!

- The QR codes are also available under the login information of the login page of our official website (www.solaxcloud.com).

Method 2: Search for **SolaXCloud** in Apple Store APP or Google Play Store, and then download the app.

10.2.2 Operation on the App

For instructions on related operations, see the online App guide, Wifi connection guide and Setup tutorial video on the SolaXCloud App.

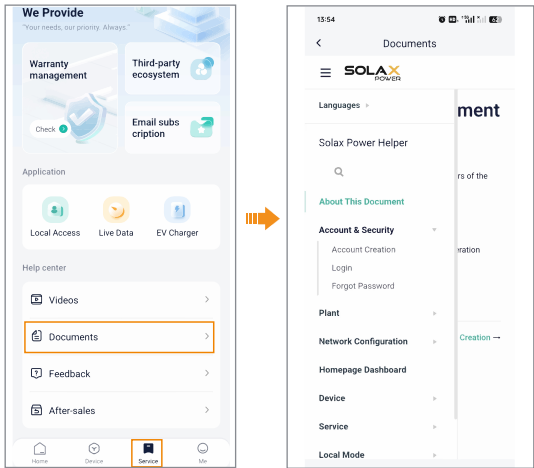

Figure 10-2 App guide on SolaXCloud

NOTICE!

- The screenshots in this chapter correspond to the SolaXCloud App V6.0.0, which might change with version update and should be subject to the actual situations.

10.3 Operations on SolaxCloud Webpage

Open a browser and enter www.solaxcloud.com to complete registration, login, add site and other related operations according to the guidelines of user guide.

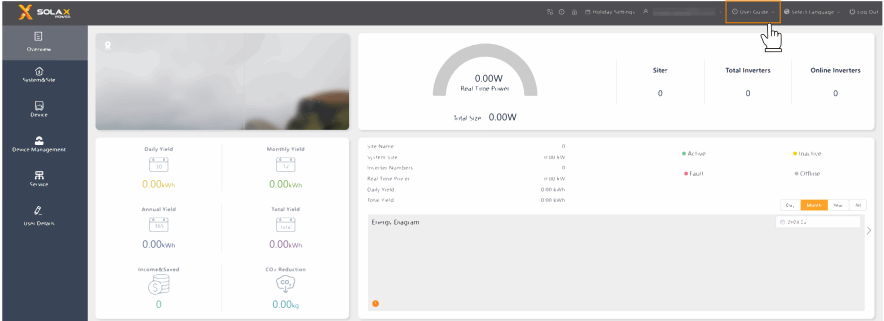

Figure 10-3 User guide on Web

11 Troubleshooting and Maintenance

11.1 Power off

- a. Turn off the AC switch between the inverter and the power grid.
- b. Set the DC switch to **OFF**.
- c. Switch off the breaker, button, DC switch.



- After the inverter is powered off, there may still be residual electricity and heat which may cause electric shocks and body burns. Please wear personal protective equipment (PPE) and start maintaining the inverter at least five minutes after power off.

11.2 Troubleshooting

This section lists the possible problems with the inverter, and provides information and procedures for identifying and resolving them. In case of any errors, check for the warnings or error messages on the system control panel or App, and then refer to the suggestions below. For further assistance, contact SolaX Customer Service. Please provide the model and SN of the inverter, and be prepared to describe the system installation details.

Table 11-1 Troubleshooting list

Error Code	Faults	Diagnosis and Solutions
IE:00001	TzFault	<p>Over Current Fault.</p> <ul style="list-style-type: none">• Wait for about 10 seconds to check if the inverter is back to normal.• Disconnect the DC switch and restart the inverter.• Or consult us for solutions.
IE:00002	GridLostFault	<p>Grid Lost Fault.</p> <ul style="list-style-type: none">• Check if the mains cable is loose.• Wait for a while and the system will reconnect when the utility is back to normal.• Or consult us for solutions.

Error Code	Faults	Diagnosis and Solutions
IE:00003 IE:00004 IE:00005 IE:00058	GridVoltFault	Grid Voltage Out of Range. <ul style="list-style-type: none"> • Check if the mains cable is loose. • Wait for a while and the system will reconnect when the utility is back to normal. • Or consult us for solutions.
IE:00006 IE:00007 IE:00008 IE:00059	GridFreqFault	Grid Frequency Out of Range. <ul style="list-style-type: none"> • Wait for a while and the system will reconnect when the utility is back to normal. • Or consult us for solutions.
IE:00009	PVVoltFault	PV voltage Fault. <ul style="list-style-type: none"> • Check whether the PV is overvoltage. • Or consult us for solutions.
IE:00010 IE:00051 IE:00052	BusVoltFault	DC Bus Voltage Out of Normal Range. <ul style="list-style-type: none"> • Check if the PV input voltage is within the operating range of the inverter. • Disconnect PV wiring and reconnect. • Or consult us for solutions.
IE:00012	GridVolt10MFault	Grid Overvoltage for Ten Minutes Fault. <ul style="list-style-type: none"> • The system will reconnect when the utility is back to normal. • Or consult us for solutions.
IE:00013	DclnjOCP	DCI Overcurrent Protection Fault. <ul style="list-style-type: none"> • Wait for a while to check if the inverter is back to normal. • Or consult us for solutions.
IE:00034	HardLimitFault	Hard Limit Fault (in Australian standard). <ul style="list-style-type: none"> • Wait for a while to check if the inverter is back to normal. • Or consult us for solutions.
IE:00018 IE:00019	ResidualOCP	Overcurrent Protection Fault. <ul style="list-style-type: none"> • Check the connections of the inverter. • Wait for a while to check if the inverter is back to normal. • Or consult us for solutions.
IE:00020	IsoFault	Isolation Fault. <ul style="list-style-type: none"> • Check the connections of the inverter. • Or consult us for solutions.

Error Code	Faults	Diagnosis and Solutions
IE:00021	OverTempFault	Over Temperature Fault. <ul style="list-style-type: none"> • Check if the inverter and the ambient temperature exceeds the operating range. • Or consult us for solutions.
IE:00055	EarthFault	Earth Fault. <ul style="list-style-type: none"> • Check if the earth is connected properly. • Or consult us for solutions.
IE:00029	LowTempFault	Low Temperature Fault. <ul style="list-style-type: none"> • Check if the ambient temperature is too low. • Or consult us for solutions.
IE:00036	InternalComFault	Internal Communication Fault. <ul style="list-style-type: none"> • Restart the inverter to check if it is back to normal. • Update the ARM software or return the program. • Or consult us for solutions.
IE:00037	EepromFault	DSP EEPROM Fault. <ul style="list-style-type: none"> • Disconnect PV wiring and reconnect. • Or consult us for solutions.
IE:00038	RcDeviceFault	Residual Current Device Fault. <ul style="list-style-type: none"> • Restart the inverter. • Update the ARM software or return the program. • Or consult us for solutions.
IE:00039 IE:00056	GridRelayFault	Relay Fault. <ul style="list-style-type: none"> • Check the grid connection. • Restart the inverter. • Or consult us for solutions.
ME:00103	Mgr EEPROM Fault	<ul style="list-style-type: none"> • ARM EEPROM Fault • Disconnect PV and grid. then reconnect. • Or consult us for solutions.
ME:00105	Meter Fault	Meter Fault. <ul style="list-style-type: none"> • Check the connection of the meter. • Check if the meter is in working order. • Or consult us for solutions.
ME:00101	PowerTypeFault	Power Type Fault <ul style="list-style-type: none"> • Check the version of ARM and DSP. • Check the product SN number. • Or consult us for solutions.

Error Code	Faults	Diagnosis and Solutions
ME:00104	Mgr Comm Fault	<p>Mgr InterCom Fault</p> <ul style="list-style-type: none"> • Shut down photovoltaic, and grid, reconnect. • Or ask for help from the installer if it can not return to normal.
IE:00016 IE:00015	SW OCP Fault	<p>Software Overcurrent Protection Fault.</p> <ul style="list-style-type: none"> • Wait for a while to check if the inverter is back to normal. • Disconnect PV and grid, then reconnect. • Or consult us for solutions.
IE:00062	CT Fault	<p>CT Fault</p> <ul style="list-style-type: none"> • Check if the meter is connected. • Turn off CT. • Or consult us for solutions.
IE:00063	METER Fault	<p>Meter Fault</p> <ul style="list-style-type: none"> • Check if the meter is connected. • Check whether the CT on the CT meter has fallen off. • Turn off CT. • Or consult us for solutions.
IE:00060	ARC Fault	<p>ARC Fault</p> <ul style="list-style-type: none"> • Turn off the ARC Enable Switch. • Wait for a while to check if the inverter is back to normal. • Or consult us for solutions.
IE:00061	ARC Self Test Fault	<p>ARC Self Test Fault</p> <ul style="list-style-type: none"> • Turn off the ARC Enable Switch. • Wait for a while to check if the inverter is back to normal. • Or consult us for solutions.
IE:00028	Fan Fault	<ul style="list-style-type: none"> • Wait for a while to check if the inverter is back to normal. • Or consult us for solutions.

11.3 Maintenance

Regular maintenance is required for the inverter. Please check and maintain the following items based on the instructions below to ensure the optimal performance of the inverter. For inverters working in inferior conditions, more frequent maintenance is required. Please keep maintenance records.



- Only qualified person can perform the maintenance for the inverter.
- Only spare parts and accessories authorized by SolaX can be used for maintenance.

11.3.1 Maintenance routines

Table 11-2 Proposal of Maintenance

Item	Check notes	Maintenance interval
Fans	<ul style="list-style-type: none"> • Check if the fan makes noise or is covered by dust. • Clean the fan with a soft and dry cloth or brush, or replace the fan if necessary. 	Every 12 months
Electrical connection	<ul style="list-style-type: none"> • Ensure that all cables are firmly connected. • Check the integrity of the cables, ensuring that there are no scratches on the parts touching the metallic surface. • Verify that the sealing caps on idle terminals are not falling off. 	Every 12 months
Grounding reliability	<ul style="list-style-type: none"> • Check if the grounding cables are firmly connected to the grounding terminals. Use a ground resistance tester to test the grounding resistance from the inverter enclosure to the PE bar in the power distribution box. 	Every 12 months
Heat sink	<ul style="list-style-type: none"> • Check if there are foreign objects in the heat sink. 	Every 12 months
General status of inverter	<ul style="list-style-type: none"> • Check if there is any damage on the inverter. • Check if there is any abnormal sound when the inverter is running. 	Every 6 months

11.3.2 Upgrading Firmware

WARNING!

- Make sure that the type and format of the firmware file are correct. Do not modify the file name. Otherwise, the inverter may not work properly.
- Do not modify the folder name and file path where the firmware files are located, as this may cause the upgrade to fail.

WARNING!

- Before upgrading, ensure that the PV input voltage is higher than 100 V (preferably on sunny day). Failure to meet this condition may result in upgrade process failure.

Upgrade preparation

- Prepare a USB drive (USB 2.0/3.0, ≤32 GB, FAT 16/32).
- Check for the current firmware version of the inverter.
- Contact our service support for the update firmware file, and save it to the USB drive.
 - » For ARM file: Update\ARM\XXXXXXXXXXXX_X1_MINI_G4_ARM_VXXX.XX_XXXXXXXXX.bin
 - » For DSP file: Update\DSP\XXXXXXXXXXXX_X1_MINI_G4_DSP_VXXX.XX_XXXXXXXXX.bin
- Check the folder name and file path:

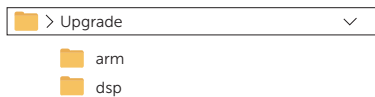
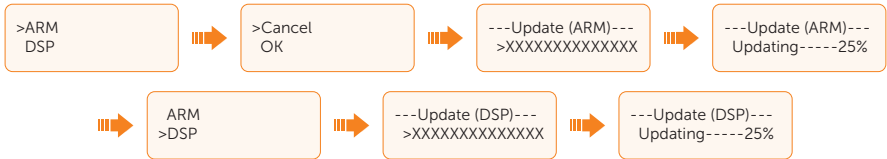

Figure 11-4 Folder name and path

Upgrade steps

- a. Remove the dongle from the Dongle terminal of the inverter by hand, and then insert the USB drive. The inverter will automatically display the **Upgrade Selection** interface. (For the position of Dongle terminal, refer to "7.1.1 Terminals of Inverter".)
- b. On the **Upgrade Selection** interface, select **ARM** or **DSP** based on the file type, and then tap **OK**. Following the steps below to update the firmware.



CAUTION!

- If the firmware upgrade fails or stops, do not unplug the USB drive. Power off the inverter, restart it, and then repeat the above upgrade steps.

NOTICE!

- If the LCD screen lags or freezes after the upgrade, turn off the DC switch, and then restart the inverter. Check if the inverter returns to normal. If not, contact us.

12 Decommissioning

12.1 Disassembling the Inverter



- Strictly follow the steps below to disassemble the inverter.
- Only use the dedicated removal tool delivered with the inverter to disassemble the AC connector, PV connector, and communication connector.

Step 1: Turn off the system by **System ON/OFF** on LCD screen.

Step 2: Disconnect the external AC breaker of the inverter.

Step 3: Turn the DC switch to OFF.

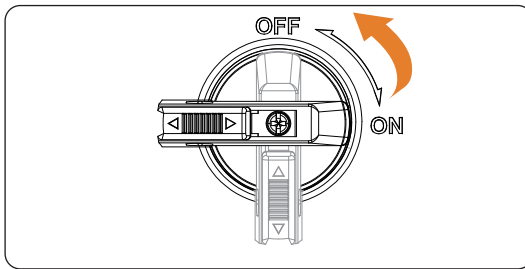

Figure 12-1 Turning off the DC switch

Step 4: Turn off the AC breaker.

Step 5: Disconnect the PV connectors: Insert the disassembling tool for PV terminal (part N) into the notch of PV connectors and slightly pull out the connectors.

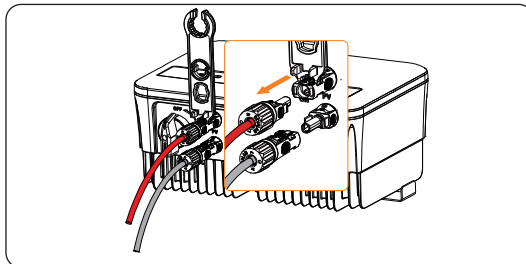

Figure 12-2 Releasing the PV connector

Step 6: Slightly pull out the dongle module.

Step 7: Disconnect the AC connector: Press the slot of the AC connector to release it. Slightly pull the connectors.

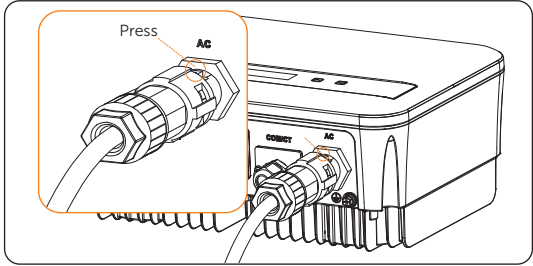

Figure 12-3 Insert the removal tool

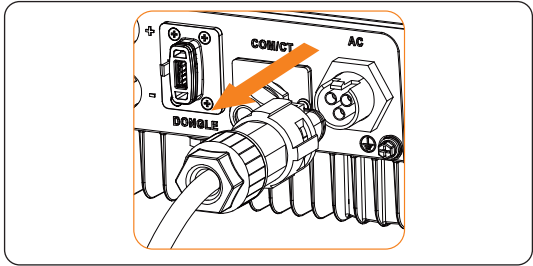

Figure 12-4 Releasing the AC connector

Step 8: Disassemble the COM/CT port and slightly pull the RJ45 connector.

Step 9: Put the original terminal caps on the terminals.

Step 10: Unscrew the grounding screw by crosshead screw and remove the grounding cable.

Step 11: Unscrew the M5 screw on the left side of inverter and vertically lift up the inverter to dismantle the inverter.

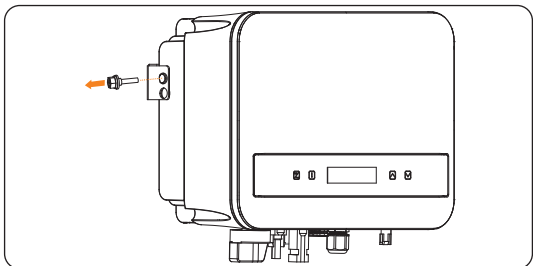

Figure 12-5 Unscrewing the M5 screws

Step 12: Unscrew the screws for fastening the wall mounting bracket and remove the wall mounting bracket if needed.

12.2 Packing the Inverter

- Use the original packaging materials if available.

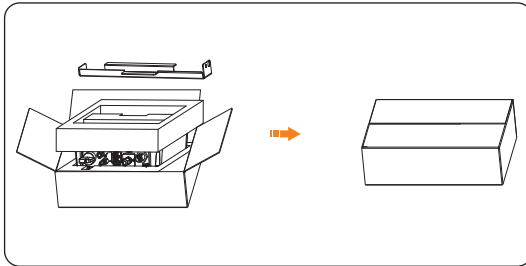

Figure 12-6 Packing the inverter

- If the original packing material is not available, use the packing material which meets the following requirements:
 - » Suitable for the weight and dimension of product
 - » Convenient for transportation
 - » Can be sealed with adhesive tape

12.3 Disposing of the Inverter

Properly dispose of the inverter and accessories in accordance with local regulations on the disposal of electronic waste.

13 Technical Data

- DC input

Model	X1-MINI-0.6K-G4	X1-MINI-0.7K-G4	X1-MINI-0.8K-G4	X1-MINI-1.1K-G4	X1-MINI-1.5K-G4
Max. PV array input power [Wp]	1200	1400	1600	2200	3000
Max. PV voltage [d.c.V]	450	450	450	450	450
Startup voltage [d.c.V]	50	50	50	50	50
Nominal input voltage [d.c.V]	360	360	360	360	360
MPPT voltage range [d.c.V]	40-450	40-450	40-450	40-450	40-450
No. of MPP trackers/Strings per MPP tracker	1/1				
Max. PV current [d.c.A]	16				
I_{sc} PV array Short Circuit SC Current [d.c.A]	22				
Max. inverter backfeed current to the array [d.c.A]	0				

Model	X1-MINI-2.0K-G4	X1-MINI-2.5K-G4	X1-MINI-3.0K-G4	X1-MINI-3.3K-G4	X1-MINI-3.7K-G4	X1-MINI-4.0K-G4
Max. PV array input power [kWp]	4000	5000	6000	6600	7400	8000
Max. PV voltage [d.c.V]	450	550	550	550	550	550
Startup voltage [d.c.V]	50	50	50	50	50	50
Nominal input voltage [d.c.V]	360	360	360	360	360	360
MPPT voltage range [d.c.V]	40-450	40-550	40-550	40-550	40-550	40-550
No. of MPP trackers/Strings per MPP tracker	1/1					
Max. PV current [d.c.A]	16					
I_{sc} PV array Short Circuit SC Current [d.c.A]	22					
Max. inverter backfeed current to the array [d.c.A]	0					

• AC output

Model	X1-MINI-0.6K-G4	X1-MINI-0.7K-G4	X1-MINI-0.8K-G4	X1-MINI-1.1K-G4	X1-MINI-1.5K-G4
Rated output apparent power [VA]	600	700	800	1100	1500
Nominal AC output current [a.c.A]	2.6	3.1	3.5	4.8	6.5
Max. output apparent power [VA]	600	770	800	1210	1650
Max. output continuous current [a.c.A]	3	3.5	3.7	5.5	7.5
Nominal AC voltage [a.c.V]/ Grid range	220/230/240; 90-290				
Nominal grid frequency [Hz]	50/60; ±5				
Displacement power factor	0.8leading-0.8lagging				
ITHDi (rated power) [%]	<3				
Current (inrush) [a.c.A]	50				
Maximum output fault current [a.c.A]	58 (15 ms)				
Maximum output overcurrent protection [a.c.A]	35				

Model	X1-MINI-2.0K-G4	X1-MINI-2.5K-G4	X1-MINI-3.0K-G4	X1-MINI-3.3K-G4	X1-MINI-3.7K-G4	X1-MINI-4.0K-G4
Rated output apparent power [VA]	2000	2500	3000	3300	3700	4000
Nominal AC output current [a.c.A]	8.7	10.9	13.1	14.4	16.1	17.4
Max. output apparent power [VA]	2200	2750	3300	3300	4070	4400
Max. output continuous current [a.c.A]	10	12.5	15	15	18.5	20
Nominal AC voltage [a.c.V]/ Grid range	220/230/240; 90-290					
Nominal grid frequency [Hz]	50/60; ±5					
Displacement power factor	0.8leading-0.8lagging					
ITHDi (rated power) [%]	<3					
Current (inrush) [a.c.A]	50					
Maximum output fault current [a.c.A]	58 (15 ms)					
Maximum output overcurrent protection [a.c.A]	35					

Technical Data

- System Data, Protection and Standard

Model	X1-MINI-0.6K-G4	X1-MINI-0.7K-G4	X1-MINI-0.8K-G4	X1-MINI-1.1K-G4	X1-MINI-1.5K-G4
Max. efficiency [%]	98	98	98	98	98
Euro. efficiency [%]	96	96	95	97	97
Standby consumption [W] @Night	<1				
Ingress protection	IP66				
Protective class	I				
Overvoltage category	II (DC), III (AC)				
Operating ambient temperature range [°C]	-25-60				
Max. operation altitude [m]	<4000				
Humidity [%]	0-100				
Typical noise emission [dB]	25	25	25	25	25
Storage temperature [°C]	-30-70				
Dimensions(WxHxD) [mm]	290x206x130				
Weight [kg]	5.2	5.2	5.2	5.2	5.2
Cooling concept ¹	Nature cooling				
Communication interfaces	RS485/DRM/USB/Heat Pump, Optional: CT/Meter				
Optional monitoring dongle	Pocket WiFi/LAN/4G				
Over/under voltage protection	YES				
DC isolation protection	YES				
Monitoring ground fault protection	YES				
Grid monitoring	YES				
DC injection monitoring	YES				
Back feed current monitoring	YES				
Residual current detection	YES				
Anti-islanding protection	YES				
Over temperature protection	YES				
SPD (PV/AC)	Type II (Optional)				
AFCI (Arc-Fault Circuit-Interruption)	Optional (AFCI type: F-I-APFE-1-1-1) ²				

Model	X1-MINI-0.6K-G4	X1-MINI-0.7K-G4	X1-MINI-0.8K-G4	X1-MINI-1.1K-G4	X1-MINI-1.5K-G4
Safety	EN/IEC62109-1/2				
EMC	EN61000-6-1/2/3/4; EN61000-3-2/3/11/12; EN55011				
Grid monitoring	IEC61727, EN50549, G98, AS 4777.2, VDE4105, CEI 0-21, VFR				
Inverter typology	Non-isolated				
Active anti-islanding method	Frequency shift				
Micro-breaker	10A				

Note:

1. For X1-MINI-3.7K-G4 and X1-MINI-4.0K-G4, internal fan is standard.

2. F-I-AFPE-1-1-1:

- Full coverage
- Integrated
- AFPE
- 1 monitored string per input port,
- 1 input port per monitored channel,
- 1 monitored channel.

ARC function is not equipped for X1-MINI-3.7K-G4 and X1-MINI-4.0K-G4.

Technical Data

Model	X1-MINI-2.0K-G4	X1-MINI-2.5K-G4	X1-MINI-3.0K-G4	X1-MINI-3.3K-G4	X1-MINI-3.7K-G4	X1-MINI-4.0K-G4
Max. efficiency [%]	98	98	98	98	98	98
Euro. efficiency [%]	97	97	97	97	97	97
Standby consumption [W] @Night	<1					
Ingress protection	IP66					
Protective class	I					
Overvoltage category	II (DC), III (AC)					
Operating ambient temperature range [°C]	-25-60					
Max. operation altitude [m]	<4000					
Humidity [%]	0-100					
Typical noise emission [dB]	25	25	25	25	30	30
Storage temperature [°C]	-30-70					
Dimensions(WxHxD) [mm]	290x206x130					
Weight [kg]	5.2	5.5	5.5	5.5	5.5	5.5
Cooling concept ¹	Nature cooling					
Communication interfaces	RS485/DRM/USB/Heat Pump, Optional: CT/Meter					
Optional monitoring dongle	Pocket WiFi/LAN/4G					
Over/under voltage protection	YES					
DC isolation protection	YES					
Monitoring ground fault protection	YES					
Grid monitoring	YES					
DC injection monitoring	YES					
Back feed current monitoring	YES					
Residual current detection	YES					
Anti-islanding protection	YES					
Over temperature protection	YES					
SPD (PV/AC)	Type II (Optional)					
AFCI (Arc-Fault Circuit-Interruption)	Optional (AFCI type: F-I-AFPE-1-1-1) ²					

Model	X1-MINI-2.0K-G4	X1-MINI-2.5K-G4	X1-MINI-3.0K-G4	X1-MINI-3.3K-G4	X1-MINI-3.7K-G4	X1-MINI-4.0K-G4
Safety	EN/IEC62109-1/2					
EMC	EN61000-6-1/2/3/4; EN61000-3-2/3/11/12; EN55011					
Grid monitoring	IEC61727, EN50549, G98, AS 4777.2, VDE4105, CEI 0-21, VFR					
Inverter typology	Non-isolated					
Active anti-islanding method	Frequency shift					
Micro-breaser	16A	20A	20A	20A	25A	25A

Note:

1. For X1-MINI-3.7K-G4 and X1-MINI-4.0K-G4, internal fan is standard.

2. F-I-AFPE-1-1-1:

- Full coverage
- Intergrated
- AFPE
- 1 monitored string per input port,
- 1 input port per monitored channel,
- 1 monitored channel.

ARC function is not equipped for X1-MINI-3.7K-G4 and X1-MINI-4.0K-G4.

14 Appendix

14.1 Application of Generator

14.1.1 Introduction of generator application

When utility power supply is unavailable, the system can seamlessly switch to the generator for power supply and continue the collaboration with the photovoltaic system to ensure the uninterrupted operation of the load.

In this case, the generator functions as the utility grid to supply power for the load, and the inverter converts the solar energy to electricity.

14.1.2 Notice for generator application

- Note 1: The generator should be equipped with an Automatic Transfer Switch (ATS), enabling it to start automatically in the event of a power outage.
- Note 2: The rated output power of the generator should be greater than the sum of the load power. If there are several inverters in parallel, the rated output power of the generator should be greater than the sum of the load power.

14.1.3 ATS control

In this operating mode, the generator functions as a substitute for the grid. There is no communication between the generator and the inverter, which means no wiring modifications are required (although the inverter cannot control the generator, either). The ATS working for the generator determines whether the generator should be turned on or off based on the status of the grid.

Wiring connection diagram

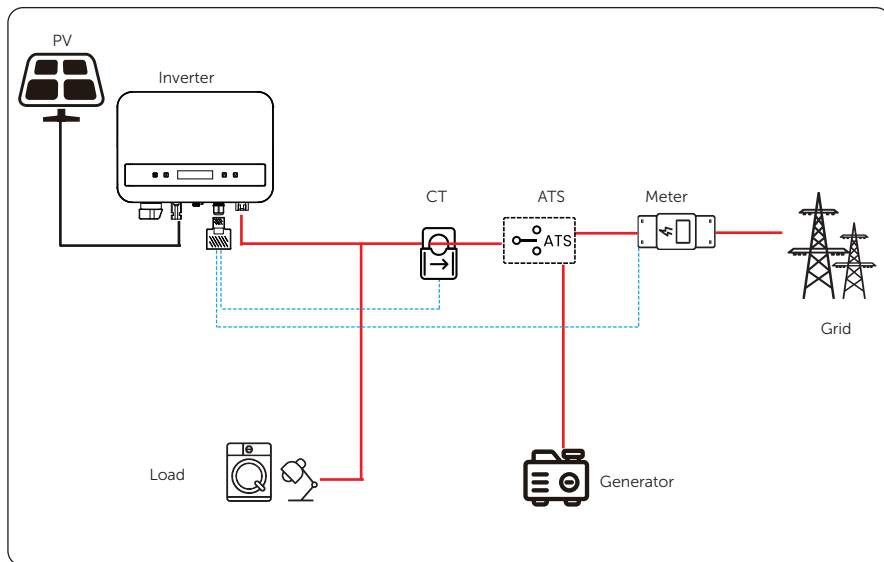

Figure 14-1 ATS control wiring diagram

Inverter settings for ATS

- a. Select **Settings > DryContact > Mode Select > Generator > ATS**.



14.2 Application of Adapter Box

14.2.1 Introduction of Adapter Box application

Adapter box is provided to control the closing and breaking of switches by giving control signals. It can also be used to control heat pump via Adapter Box.

Wiring connection diagram

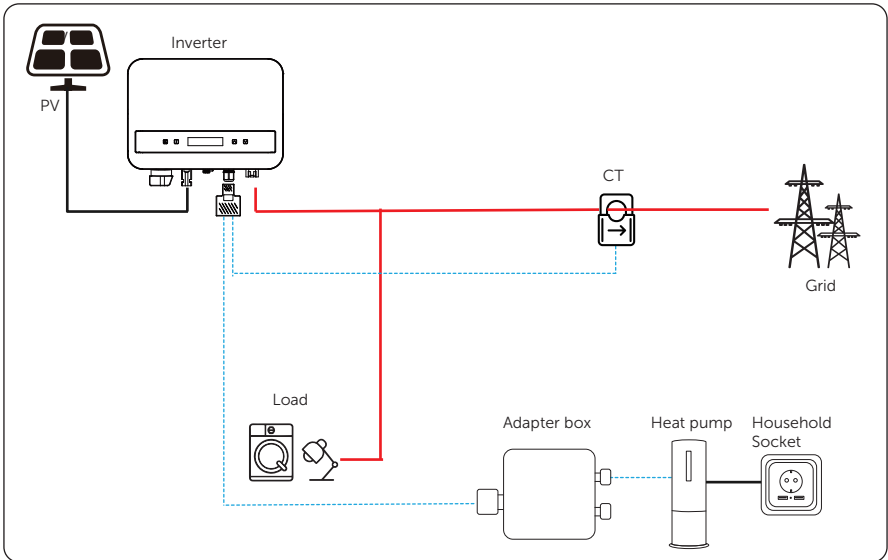

Figure 14-1 Adapter box wiring diagram

Table 14-3 PIN definition of adapter box

PIN	1	2	3	4	5	6	7	8
Definition	X	X	Heat Pump-	X	X	Heat Pump+	X	X

Connection steps

Step 1: Connect Heat Pump+ to the positive pole of the heat pump load and connect Heat Pump- to the negative pole of the heat pump load.

NOTICE!

- The heat pump function is disabled by default. Please enable it in the setting.

Inverter settings for Adapter Box

- a. Enter the **Settings** interface and choose **DryContact**.



- b. Choose **Load Management** after you enter the **DryContact** interface.

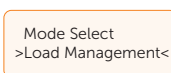

- c. There are two methods of enabling the heat pump function, **Manual** and **Smart Save**. Manual mode means to enable/disable the function manually; Smart Save means to enable/disable the function by presetting.

1. Manual Mode

- » Choose **ON** to switch on the heat pump function.



2. Smart Save Mode

- » Choose **Smart Save** mode.

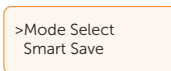

- » Set **Feedin power** according to the users' need. **Feedin power** means the electricity-selling power. When the electricity-selling power reaches the set value, heat pump will be turned on.

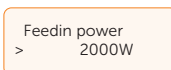

- » Set **consumption** according to the users' need. **consumption** means the electricity-buying power. When the electricity-buying power reaches the set value, heat pump will be turned off.

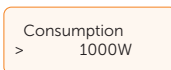

- » Set **per on-signal** according to the users' need. **per on-signal** means the minimum working period each time of heat pump.

Per on-signal
> 30 min

- » Set **per day** according to the users' needs. **per day** means the maximum working period each time of heat pump.

Per day
> 30 min

- » Enable the **Schedule** to make the system working according to the schedule as set.

Schedule
> Enable<

- » Set the time intervals for opening and closing the heat pump.

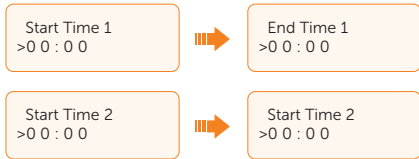

14.3 Application of Adapter Box G2

14.3.1 Introduction of Adapter Box G2 application

With the SolaX Adapter Box G2, users can effectively utilize solar energy by commanding it to power their heat pump using settings available on the SolaX inverter and SolaXCloud. This intelligent integration allows for optimized solar self-consumption and ultimately helps in reducing electricity bills.

Wiring connection diagram

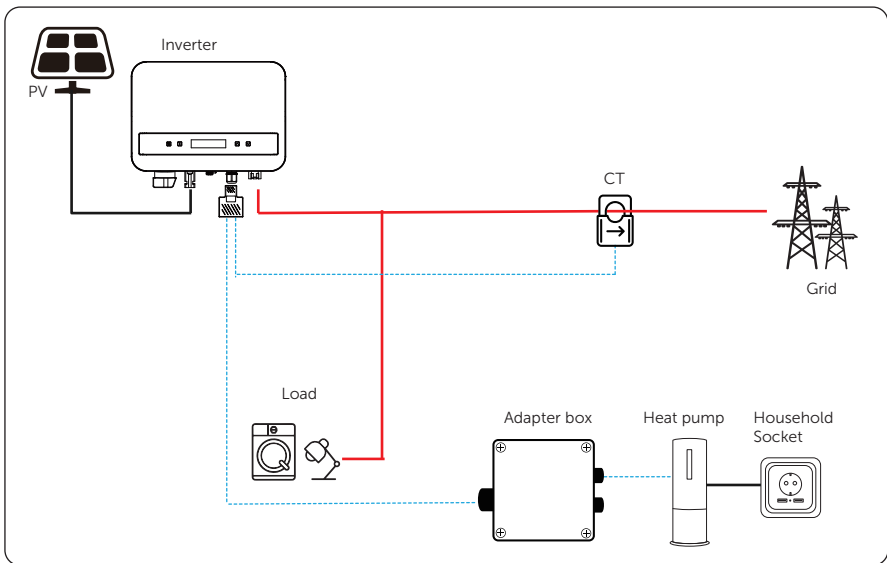

Figure 14-1 Adapter Box G2 wiring diagram

The inverter communicates with Adapter Box G2 via RS485. In case of excess power, the Adapter Box G2 can utilize it to heat the pump through the connection of dry contacts, SG Ready, or Analog output between the Adapter Box G2 and the heat pump. To power the Adapter Box G2, an external power adapter is required as the inverter itself cannot supply power to the Adapter Box G2.

Table 14-4 PIN definition of Adapter Box G2

Section of COM/CT port of the inverter		RS485-INV port of Adapter Box G2	
PIN	PIN definition	PIN	PIN definition
4	RS485A	4	RS485-A
5	RS485B	5	RS485-B

Connection step

- Step 1:** Firstly unscrew the screw from the COM/CT port. (PH1 cross screwdriver. Torque: $1.0 \pm 0.1 \text{N.m}$).
- Step 2:** Prepare a communication cable and strip the insulation layer.
- Step 3:** Thread the communication cable through the waterproof connector, then insert it into the connector following the PIN definition rule.
- Step 4:** Crimp the RJ45 (part E) with the crimping plier.
- Step 5:** Insert the cable into the COM/CT port of the inverter, screw down the screw on the port and tighten the waterproof connector.

For specific wiring procedures of Adapter Box G2, see *Adapter Box G2 User Manual*.

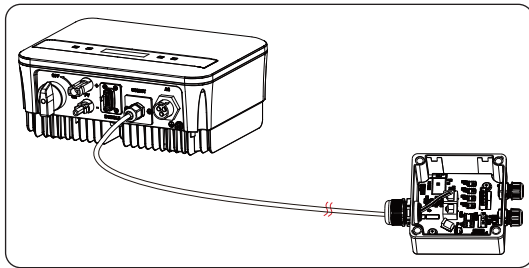

Figure 14-2 Adapter Box G2 connection

NOTICE!

- The communication cable between Adapter Box G2 and inverter can not exceed 100 m.

14.3.2 Settings for Adapter Box G2

- a. Select **Settings > Adapter Box G2 > Mode Select > Enable**.

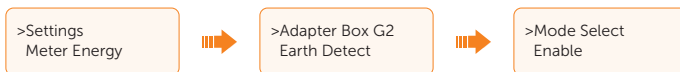

NOTICE!

- For specific setting procedures of Adapter Box G2, see *Adapter Box G2 User Manual*.

14.4 Application of EV-Charger

14.4.1 Introduction of EV-Charger application

The EV-Charger is intended for charging electric vehicles. It should be installed in a fixed location and connected to the AC supply. The inverter can communicate with the smart EV-Charger to form an intelligent photovoltaic and EV charging energy system, thus maximizing the utilization of photovoltaic energy.

Wiring connection diagram

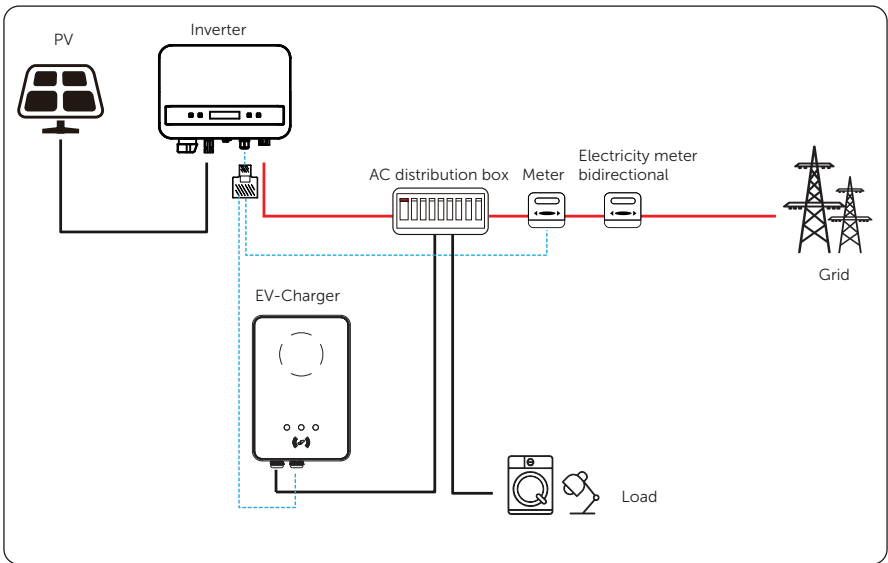

Figure 14-3 EV-Charger wiring diagram

Connection steps

Step 1: Plug one terminal of the communication cable to the right pin of the EVCharger and the other terminal to PIN 4 & 5 of the "COM/CT" port of the inverter.

Step 2: Connect the meter to PIN 4 & 5 of the "COM/CT" port of the inverter.

14.4.2 Setting for EV-Charger

Turn on the power of the entire system, enter the **Settings** page of the inverters on the LCD screen.

- a. Enter the **Export Control** page and chose **CT** or **Meter**.



- b. Select **EvChargerEnable** and then enter **Mode Select**. Ensure the interface shows **Enable** under **Mode Select**, which indicate the EVCharger function started successfully.



NOTICE!

- For specific wiring and setting procedures of EV-Charger, see *X1/X3-EVC Series User Manual*.

14.5 Application of Parallel Connection

The series inverter provides the parallel connection function, which could support several inverters to parallel in one system and can control zero injection to the grid with a meter installed in the main circuit. The parallel system can be achieved with Modbus Function or with Databus.

14.5.1 Parallel System with Modbus Function

In this parallel system, at most 5 inverters can be connected. One inverter will be set as a master, and the rest are the slaves. The master inverter can communicate with all the slave inverters.

Wiring diagram

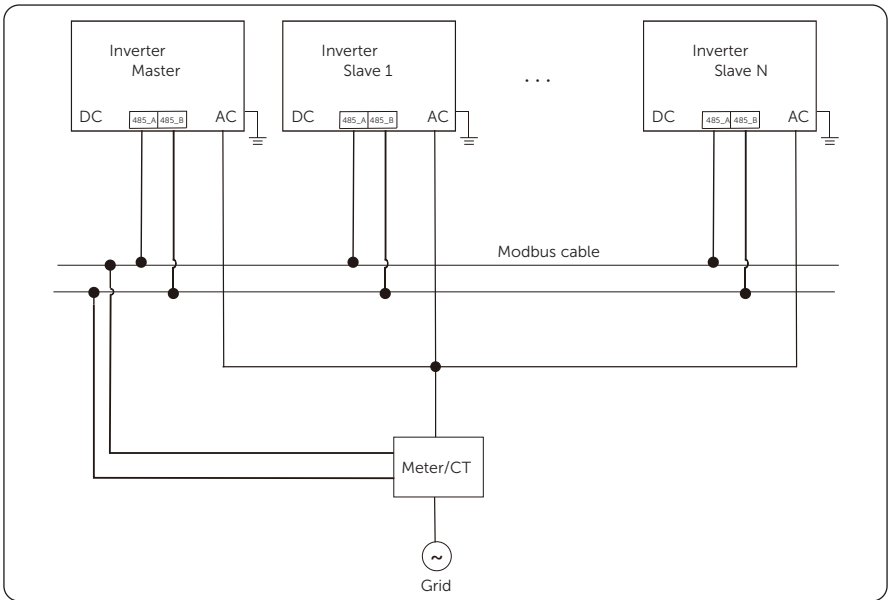

Figure 14-4 Wiring diagram-Parallel system with modbus function

NOTICE!

Before operation, please make sure that the inverters meet the following condition:

- All the inverters shall be the same series;
- The firmware version of all inverters shall be the same. Otherwise, the parallel function cannot be used.

Wiring procedure

- Step 1:** Connect all the inverters in the parallel system with each other via RS485 cables.
- Step 2:** Connect the communication cable with the master inverter.

Inverter setting for parallel system with Modbus function

Turn on the power of the entire system, enter setting page of the inverters on the LCD screen. Follow the instructions below to finish the settings.

- To set the master inverter:
 - Enter **ParallelSetting** page, choose **Enable** to activate the function for the inverter.



- Make sure the meter/CT is connected to the master inverter. Enter the **Export Control** page and choose **Meter/CT** on the master inverter.



- Choose **M/S Mode** to select the Master inverter. Only one inverter can be set as **Master**.



- Set the value for **System Limit** on the master inverter. This will be the overall power limit for parallel system. The output power of slaves will then be distributed respectively according to their nominal output power. The value can be set within the range of 0 kW to 30 kW and the default value is 0 W.

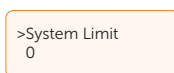

- At most 5 inverters can be set in this parallel system.
 - » If single phase meter is used, set the parallel number of inverters.

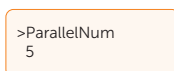

- » If three phase meter is used, set the parallel number of inverters for R, S, T phases separately.

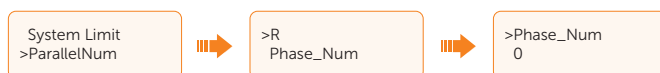

- To set the slave inverters:

- a. Enter **Export Control** page, and the mode status is **Disable** by default (users cannot set by themselves).



- b. Choose **ParallelSetting** and then set the status of **Parallel Switch** as **Enable**.



- c. Enter **M/S Mode** and chose **Slave** to set the Slave inverters.

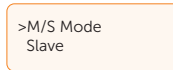

- d. If three phase meter is used, select the phase for master inverters. If single phase meter is used, skip this step.

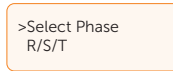

- e. If three phase meter is used, set the RS485 address for each master inverters. The RS485 address ranges from 2 to 5.

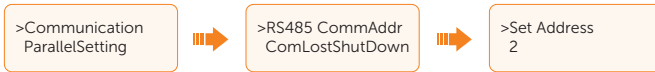

NOTICE!

- The power limit value set in **System Limit** is the limit for the multiple inverters in the parallel system, while the **UserValue** set in **Export Control** is the power limit for a single inverter which will be nullified when the parallel function is enabled.

14.5.2 Parallel system with DataHub

In this parallel system, at most 60 inverters can be connected. The Datahub will be the master of the system, and all the inverters are the slaves. The Datahub can communicate with all the slave inverters.

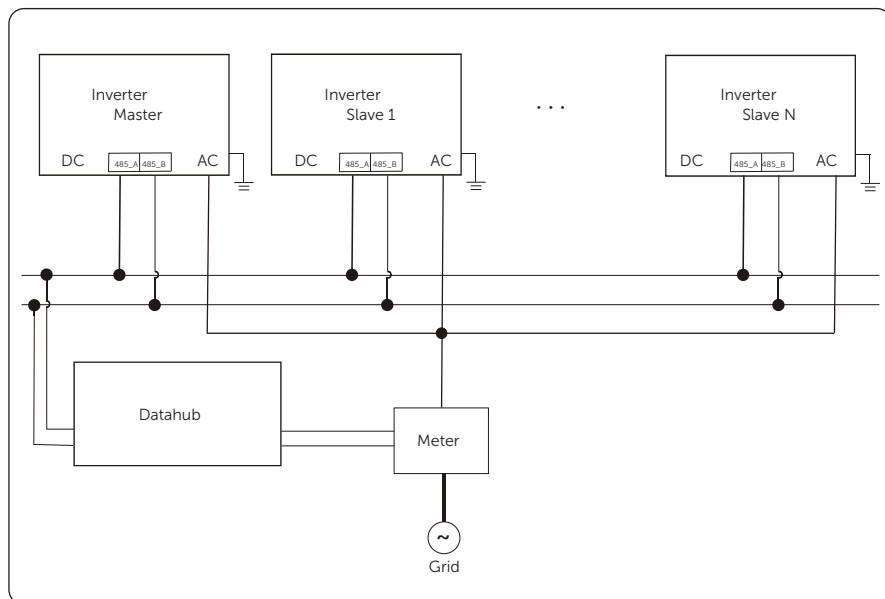

Figure 14-5 Wiring diagram-Parallel system with DataHub

NOTICE!

Before operation, please make sure that the inverters meet the following condition:

- The **ParallelSetting** should be **Disable**.
- The addresses of all the inverters should be different. Otherwise, please reset the RS485 communication addresses.
- The communication address of meter and inverter mustn't be the same, otherwise a conflict may arise.

Wiring procedure

Step 1: Connect one terminal of an RS485 communication cable with Datahub, and the other end with one of the slave inverters.

Step 2: Connect all the slave inverters with each other via RS485 cables.

Step 3: Connect the meter with the DataHub and the MAINS.

NOTICE!

- The inverter connected with the Datahub should not enable the **ParallelSetting**.
- There is no need to set the **ParallelSetting** on the inverters, the parallel system with Datahub will start automatically.

For detail settings, please refer to *the User Manual or Quick Installation Guide of DataHub 1000*.



SolaX Power Network Technology (Zhejiang) Co., Ltd.

ADD.: No. 278, Shizhu Road, Chengnan Sub-district, Tonglu County,
Hangzhou, Zhejiang, China
E-mail: info@solaxpower.com